

HP Pavilion dm1
HP Mini 311
Compaq Mini 311
Maintenance and Service Guide

Document Part Number: 574404-002

October 2009

This guide is a troubleshooting reference used for maintaining and servicing the computer. It provides comprehensive information on identifying computer features, components, and spare parts; troubleshooting computer problems; and performing computer disassembly procedures.

© Copyright 2009 Hewlett-Packard Development Company, L.P.

Bluetooth is a trademark owned by its proprietor and used by Hewlett-Packard Company under license. Intel, Atom, Celeron, and Pentium are trademarks of Intel Corporation in the U.S. and other countries. Microsoft and Windows are U.S. registered trademarks of Microsoft Corporation. SD Logo is a trademark of its proprietor.

The information contained herein is subject to change without notice. The only warranties for HP products and services are set forth in the express warranty statements accompanying such products and services. Nothing herein should be construed as constituting an additional warranty. HP shall not be liable for technical or editorial errors or omissions contained herein.

Second Edition: October 2009

First Edition: September 2009

Document Part Number: 574404-002

Safety warning notice



WARNING: To reduce the possibility of heat-related injuries or of overheating the computer, do not place the computer directly on your lap or obstruct the computer air vents. Use the computer only on a hard, flat surface. Do not allow another hard surface, such as an adjoining optional printer, or a soft surface, such as pillows or rugs or clothing, to block airflow. Also, do not allow the AC adapter to contact the skin or a soft surface, such as pillows or rugs or clothing, during operation. The computer and the AC adapter comply with the user-accessible surface temperature limits defined by the International Standard for Safety of Information Technology Equipment (IEC 60950).

1 Product description

2 External component identification

Display	2-1
Display components	2-1
Wireless antennas	2-2
Top components	2-3
Buttons	2-3
Keys	2-4
Lights	2-5
Pointing devices	2-6
Front components	2-7
Right-side components	2-8
Left-side components	2-9
Bottom components	2-10

3 Illustrated parts catalog

Service tag	3-1
Computer major components	3-2
Display assembly subcomponents	3-9
Miscellaneous parts	3-10
Sequential part number listing	3-11

4 Removal and replacement procedures

Preliminary replacement requirements	4-1
Tools required	4-1
Service considerations	4-1
Grounding guidelines	4-2
Component replacement procedures	4-5
Service tag	4-5
Computer feet	4-6
Battery	4-7
SIM	4-8
WLAN module	4-9
WWAN module	4-13
RTC battery	4-15
Expansion memory module	4-16
Hard drive	4-18
Keyboard	4-21
Top cover	4-24
Wireless button board	4-27
Power button board	4-28

Speakers	4-29
Digital media assembly	4-30
Display assembly	4-31
Multi board	4-37
System board	4-38
Power connector	4-41
Fan	4-42
Heat sink assembly	4-43
5 Setup Utility	
Starting Setup Utility	5-1
Using Setup Utility	5-1
Changing the language of Setup Utility	5-1
Navigating and selecting in Setup Utility	5-1
Displaying system information	5-2
Restoring factory settings in Setup Utility	5-2
Exiting Setup Utility	5-2
Setup Utility menus	5-3
Main menu	5-3
Security menu	5-3
Diagnostics menu	5-3
System Configuration menu	5-4
6 Specifications	
Computer specifications	6-1
11.6-in display specifications	6-2
Hard drive specifications	6-3
DVD±RW and CD-RW SuperMulti Double-Layer Combo Drive with LightScribe specifications	6-4
Blu-ray ROM with LightScribe DVD±R/RW SuperMulti Double-Layer Drive specifications	6-5
System DMA specifications	6-6
System memory map specifications	6-6
System interrupt specifications	6-7
System I/O address specifications	6-8
7 Screw listing	
Phillips PM2.0×4.0 screw	7-2
Phillips PM2.0×5.0 screw	7-6
Phillips PM2.0×6.0 captive screw	7-7
Phillips PM2.0×7.0 screw	7-10
Phillips PM2.0×12.0 screw	7-13
Phillips PM3.0×4.0 screw	7-14
8 Backup and recovery	
Backup and recovery in Windows 7	8-1
Overview	8-1
Creating recovery discs	8-2
Backing up your information	8-2
Performing a recovery	8-4
Backup and recovery in Windows XP	8-5
Overview	8-5

Backing up your information	8-5
Performing a recovery	8-6

9 Connector pin assignments

Audio-out (headphone)/Audio-in (microphone)	9-1
External monitor	9-2
HDMI	9-3
RJ-45 (network)	9-4
Universal Serial Bus	9-4

10 Power cord set requirements

Requirements for all countries and regions	10-1
Requirements for specific countries and regions	10-2

11 Recycling

Battery	11-1
Display	11-1

Index

Product description

Category	Description	HP Mini 311	Compaq Mini 311	HP Pavilion dm1
Processors	Intel® Atom™ N280 1.66-GHz, 512-KB L2 cache, 667-MHz front-side bus (FSB)	✓	✓	
	Intel Atom N270 1.60-GHz, 512-KB L2 cache, 533-MHz front-side bus (FSB)	✓	✓	
	Intel Pentium® SU4100 1.3-GHz, 2048-KB L2 cache, 800-MHz front-side bus (FSB)			✓
	Intel Mobil Celeron® SU2300 1.2-GHz, 1024-KB L2 cache, 800-MHz front-side bus (FSB)			✓
Chipset	MCP79	✓	✓	
	Intel GS45 (8W)			✓
	Southbridge ICH9M			✓
Graphics	nVidia ION (Windows 7 only)	✓	✓	
	nVidia ION LE (Windows XP only)	✓	✓	
	Intel UMA graphics (Mobile Intel GMA X4500 HD) Integrated with shared video memory:	✓	✓	✓
	■ Up to 270-MB for 1024-MB system RAM			✓
	■ Up to 319-MB for 1024-MB system RAM	✓	✓	
	■ Up to 782-MB for 2048-MB system RAM			✓
	■ Up to 895-MB for 2048-MB system RAM	✓	✓	
	■ Up to 1294-MB for 3072-MB system RAM			✓
	■ Up to 1294-MB for 4096-MB system RAM (32 bit OS)			✓
	■ Up to 1407-MB for 3072-MB system RAM	✓	✓	
■ Up to 1759-MB for 4096-MB system RAM (64 bit OS)			✓	
	Support for BD and HD-DVD playback with HD decode and DX10.1 support			✓

(Continued)

Category	Description	HP Mini 311	Compaq Mini 311	HP Pavilion dm1
Panel	11.6-in (1366 × 768) HD, BrightView, LED display assembly, supports privacy filter	✓	✓	✓
Memory	1024-MB on-board memory and one customer-accessible/upgradable memory module slot Supports dual-channel memory Supports the following DDR3 configurations at 1333 MHz:	✓	✓	✓
	■ 5120-MB total system memory (1024 on-board memory + 4096, dual channel)			✓
	■ 3072-MB total system memory (1024 on-board memory + 2048, dual-channel)	✓	✓	✓
	■ 2048-MB total system memory (1024 on-board memory + 1024, dual-channel)	✓	✓	✓
	■ 1024-MB total system memory (1024 on-board memory, dual-channel)	✓	✓	✓
	Supports the following DDR3 configurations at 1066 MHz:			
	■ 5120-MB total system memory (1024 on-board memory + 4096, dual channel)			✓
	■ 3072-MB total system memory (1024 on-board memory + 2048, dual-channel)	✓	✓	✓
	■ 2048-MB total system memory (1024 on-board memory + 1024, dual-channel)	✓	✓	✓
	■ 1024-MB total system memory (1024 on-board memory, dual-channel)	✓	✓	✓
Solid-state drive	Supports 80-GB solid-state drive	✓	✓	✓
Hard drives	Supports 9.50-mm, 6.35-cm (2.50-in) hard drives Supports HP ProtectSmart Hard Drive Protection Customer-accessible Serial ATA (SATA)	✓	✓	✓
	Supports the following hard drives:			
	■ 500-GB, 5400-rpm			✓
	■ 320-GB, 5400-rpm (Windows 7 only)	✓	✓	✓
	■ 250-GB, 5400-rpm (Windows 7 only)	✓	✓	✓
	■ 160-GB, 7200-rpm	✓	✓	✓
	■ 160-GB, 5400-rpm	✓	✓	✓

(Continued)

Category	Description	HP Mini 311	Compaq Mini 311	HP Pavilion dm1
Optical drives	12.7-mm tray load external USB optical drive Serial ATA (SATA) Customer-accessible Supports no-optical-drive option	✓	✓	✓
	Supports the following drives:			
	■ Blu-ray ROM with LightScribe DVD±R/RW and CD-RW SuperMulti Double-Layer Drive	✓	✓	✓
	■ DVD±RW and CD-RW SuperMulti Double-Layer Drive with LightScribe	✓	✓	✓
Diskette drive	Supports external USB drive only Supports boot from USB device	✓	✓	✓
Microphone	Integrated dual-array digital microphone	✓	✓	✓
Audio	2 integrated HD stereo speakers Headphone jack Microphone jack	✓	✓	✓
Webcam	Integrated 2.8-megapixel camera with fixed focus	✓	✓	✓
Modem	Supports external USB modem option	✓	✓	✓
Ethernet	Integrated Realtek10/100 network interface card (NIC) Ethernet cable not included	✓	✓	✓

(Continued)

Category	Description	HP Mini 311	Compaq Mini 311	HP Pavilion dm1
Wireless	Integrated wireless local-area network (WLAN) options through Mini PCI module:	✓	✓	✓
	■ 802.11a/b/g/n WLAN module	✓	✓	✓
	■ 802.11a/b/g/n WLAN/ Bluetooth® combo module	✓	✓	✓
	■ 802.11b/g WLAN module	✓	✓	✓
	■ 802.11b/g WLAN/ Bluetooth combo module			✓
	Supports no-WLAN option	✓	✓	✓
	2 WLAN antennas built into the display assembly	✓	✓	✓
External media cards	Integrated wireless wide-area network (WWAN) option through Mini PCI module: WWAN security provided by subscriber identity module (SIM), user-accessible behind battery 2 WWAN antennas (worldwide, 5-band) built into the display assembly Does not support WWAN aftermarket option	✓	✓	✓
	Integrated wireless personal area network (WPAN) options through Bluetooth® module	✓	✓	✓
External media cards	One ExpressCard slot, supporting optional ExpressCard/34 cards Digital Media Slot supporting the following optional digital card formats: ■ Memory Stick (MS) ■ Memory Stick Pro (MS/Pro) ■ MultiMediaCard (MMC) ■ Secure Digital High Capacity (SDHC) Memory Card ■ xD-Picture Card (XD)	✓	✓	✓
Ports	Audio-in (stereo microphone)/Audio-out (stereo headphone) HDMI v.1.3 AC power RJ-45 (Ethernet, includes link and activity lights) USB v. 2.0 (3) VGA (Dsub 15-pin) supporting 1600 × 1200 external resolution at 75 GHz	✓	✓	✓
Keyboard/ pointing devices	Spill-resistant keyboard TouchPad with TouchPad buttons Touch-sensitive controls Supports 2-way scroll with legend Taps enabled by default	✓	✓	✓
Power requirements	65-W AC adapter 6-cell, 2.55-Ah (55-Wh) Li-ion battery	✓	✓	✓

(Continued)

Category	Description	HP Mini 311	Compaq Mini 311	HP Pavilion dm1
Security	Security cable slot	✓	✓	✓
Operating system	Preinstalled:			
	■ Free DOS (Windows 7 only)	✓	✓	✓
	■ Windows® 7 Professional 32	✓	✓	
	■ Windows 7 Premium 32	✓	✓	✓
	■ Windows 7 Basic 32	✓	✓	✓
	■ Windows 7 Starter 32	✓	✓	
	■ Free DOS (Windows XP only)	✓	✓	
	■ Windows XP Home Service Pack 3 for ULCPC Program			
	■ Back on Track			✓
Serviceability	End-user replaceable parts:	✓	✓	✓
	AC adapter			
	Battery (system)			
	Hard drive			
	Memory modules			
	SIM			
	WLAN module			
	WWAN module			

External component identification

Display

Display components

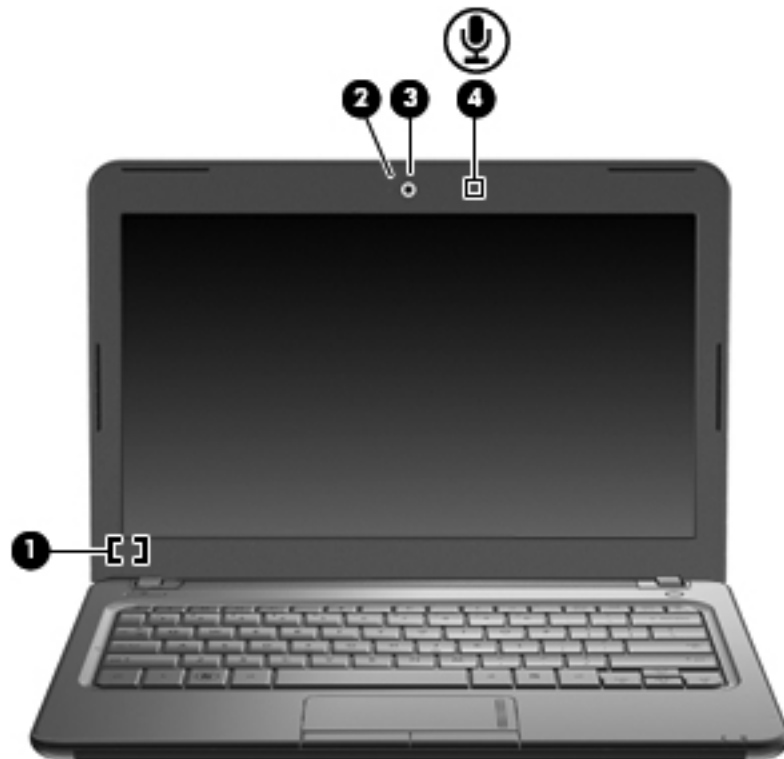

Item	Component	Description
(1)	Internal display switch	Turns off the display if the display is closed while the power is on.
(2)	Webcam light	On: The webcam is in use.
(3)	Webcam	Captures still photographs and videos.  To capture videos, you must install additional webcam software.
(4)	Internal microphone	Records sound.

Wireless antennas



Your computer may look slightly different from the illustration in this section.

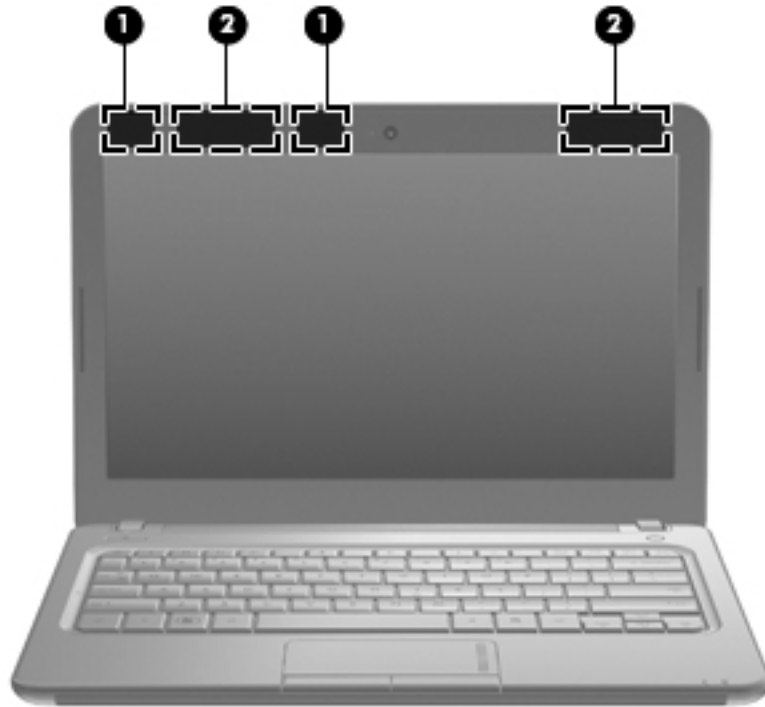

Item	Component	Description
(1)	WLAN antennas (2)*	Send and receive wireless signals to communicate with wireless local area networks (WLAN).
(2)	WWAN antennas (2)* (select models only)	Send and receive wireless signals to communicate with wireless wide-area networks (WWAN).



*The antennas are not visible from the outside of the computer. For optimal transmission, keep the areas immediately around the antennas free from obstructions.

To see wireless regulation notices, refer to the section of the *Regulatory, Safety and Environmental Notices* that applies to your country or region. These notices are located in Help and Support.

Top components

Buttons



Item	Component	Description
(1)	Power button	<ul style="list-style-type: none"> ■ When the computer is off, press the button to turn on the computer. ■ When the computer is on, press the button briefly to initiate the Sleep state or Standby. ■ When the computer is in the Sleep state or Standby, press the button briefly to exit. ■ When the computer is in Hibernation, press the button briefly to exit Hibernation. <p>If the computer has stopped responding and operating system shutdown procedures are ineffective, press and hold the power button for at least 5 seconds to turn off the computer.</p> <p> This describes factory settings. For information about changing factory settings, refer to the user guides located in Help and Support.</p>
(2)	Wireless button	<p>Turns the wireless feature on or off but does not create a wireless connection.</p> <p> To establish a wireless connection, a wireless network must already be set up.</p>

Keys



Your computer may look slightly different from the illustration in this section.

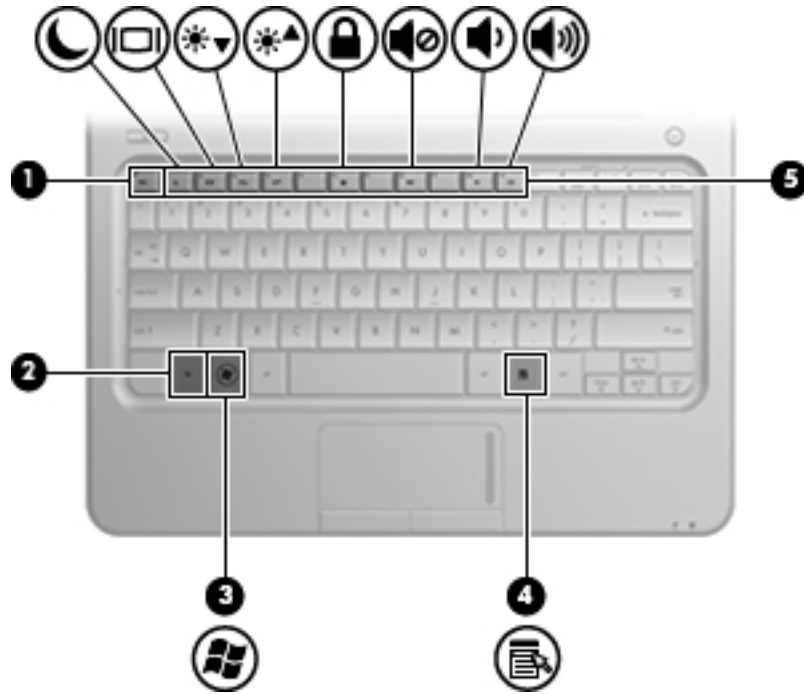

Item	Component	Description
(1)	esc key	Displays system information when pressed in combination with the fn key.
(2)	fn key	Executes frequently used system functions when pressed in combination with a function key or the esc key.
(3)	Windows logo key	Displays the Windows Start menu.
(4)	Windows applications key	Displays a shortcut menu for items beneath the pointer.
(5)	Function keys	Execute frequently used system functions when pressed in combination with the fn key.

Lights



Item	Component	Description
(1)	Caps lock light	On: Caps lock is on.
(2)	Power light	<ul style="list-style-type: none"> ■ On: The computer is on. ■ Blinking: The computer is in the Sleep state or Standby. ■ Off: The computer is off or in Hibernation.
(3)	Wireless light	<ul style="list-style-type: none"> ■ On: An integrated wireless device, such as a wireless local area network (WLAN) device and/or a Bluetooth® device, is on. ■ Off: All wireless devices are off.

Pointing devices



Item	Component	Description
(1)	TouchPad*	Moves the pointer and selects or activates items on the screen.
(2)	Left TouchPad button*	Functions like the left button on an external mouse.
(3)	Right TouchPad button*	Functions like the right button on an external mouse.
(4)	TouchPad scroll zone	Scrolls up or down.

*This table describes factory settings.

Front components



Item	Component	Description
(1)	Speakers (2)	Produce sound.
(2)	Battery light	<ul style="list-style-type: none"> ■ On: A battery is charging. ■ Blinking: A battery that is the only available power source has reached a low battery level. When the battery reaches a critical battery level, the battery light begins blinking rapidly. ■ Off: If the computer is plugged into an external power source, the light turns off when all batteries in the computer are fully charged. If the computer is not plugged into an external power source, the light stays off until the battery reaches a low battery level.
(3)	Drive light	Blinking: The hard drive or flash drive is being accessed.

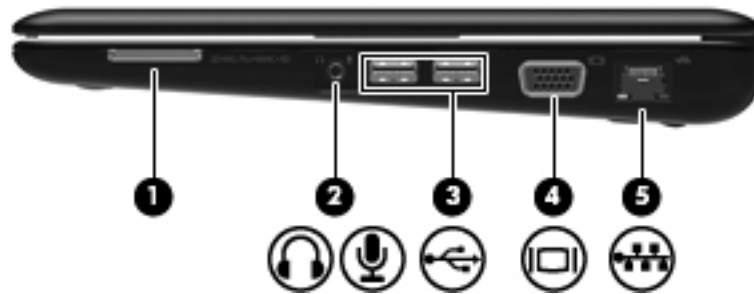

Right-side components



Item	Component	Description
(1)	Digital Media Slot	<p>Supports the following optional digital card formats:</p> <ul style="list-style-type: none"> ■ Memory Stick (MS) ■ Memory Stick Pro (MS/Pro) ■ MultiMediaCard (MMC) ■ Secure Digital (SD) Memory Card ■ xD-Picture Card
(2)	Audio-out (headphone) jack/Audio-in (microphone) jack	<p>Produces sound when connected to optional powered stereo speakers, headphones, earbuds, a headset, or television audio. Also connects an optional headset microphone.</p> <p> When a device is connected to the jack, the computer speakers are disabled.</p> <p>The audio component cable must have a 4-conductor connector.</p>
(3)	USB ports (2)	Connect optional USB devices.
(4)	External monitor port	Connects an external VGA monitor or projector.
(5)	RJ-45 (network) jack	Connects a network cable.

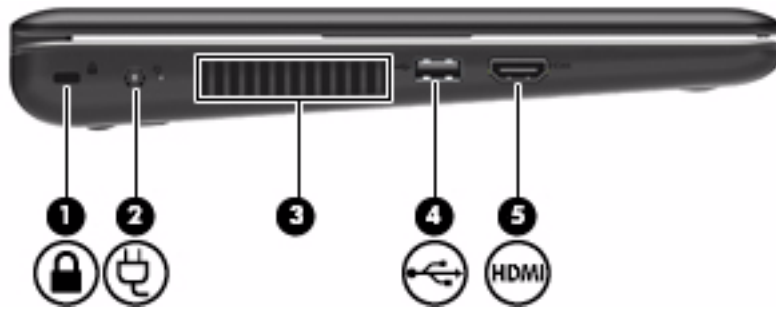

Left-side components

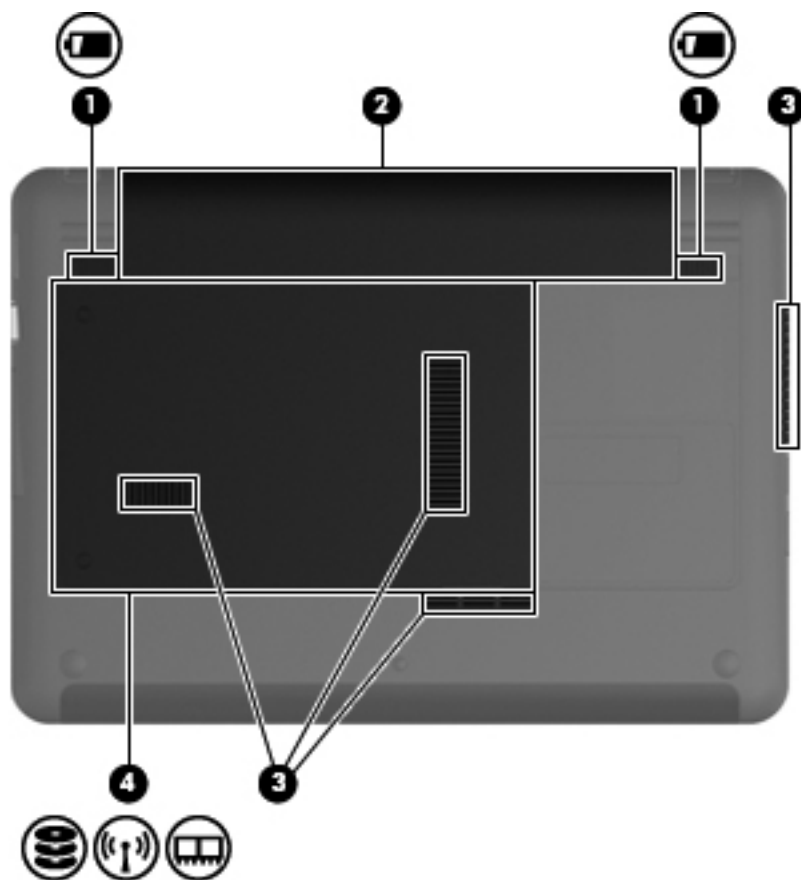

Item	Component	Description
(1)	Security cable slot	Attaches an optional security cable to the computer.  The security cable is designed to act as a deterrent, but it may not prevent the computer from being mishandled or stolen.
(2)	Power connector	Connects an AC adapter.
(3)	Vent	Enables airflow to cool internal components.  The computer fan starts up automatically to cool internal components and prevent overheating. It is normal for the internal fan to cycle on and off during routine operation.
(4)	USB port	Connects an optional USB device.
(5)	HDMI port	Connects an optional video or audio device, such as a high-definition television, or any compatible digital or audio component.  Depending on your computer model, the computer may include an HDMI port or a USB port at this location.

Bottom components



Item	Component	Description
(1)	Battery release latches (2)	Release the battery from the battery bay.
(2)	Battery bay	Holds the battery.
(3)	Vents (4)	<p>Enable airflow to cool internal components.</p> <p> The computer fan starts up automatically to cool internal components and prevent overheating. It is normal for the internal fan to cycle on and off during routine operation.</p>
(4)	Hard drive bay	<p>Contains the hard drive, the wireless LAN module slot, and the memory module slot.</p> <p> To prevent an unresponsive system, replace the wireless module only with a wireless module authorized for use in the computer by the governmental agency that regulates wireless devices in your country or region. If you replace the module and then receive a warning message, remove the module to restore computer functionality, and then contact technical support through Help and Support.</p>

Illustrated parts catalog

Service tag

When ordering parts or requesting information, provide the computer serial number and model number provided on the service tag.



Item	Component	Description
(1)	Product name	This is the product name affixed to the front of the computer.
(2)	Serial number (s/n)	This is an alphanumeric identifier that is unique to each product.
(3)	Part number/Product number (p/n)	This number provides specific information about the product's hardware components. The part number helps a service technician determine what components and parts are needed.
(4)	Model description	This is the alphanumeric identifier used to locate documents, drivers, and support for the computer.
(5)	Warranty period	This number describes the duration of the warranty period for the computer.

Computer major components

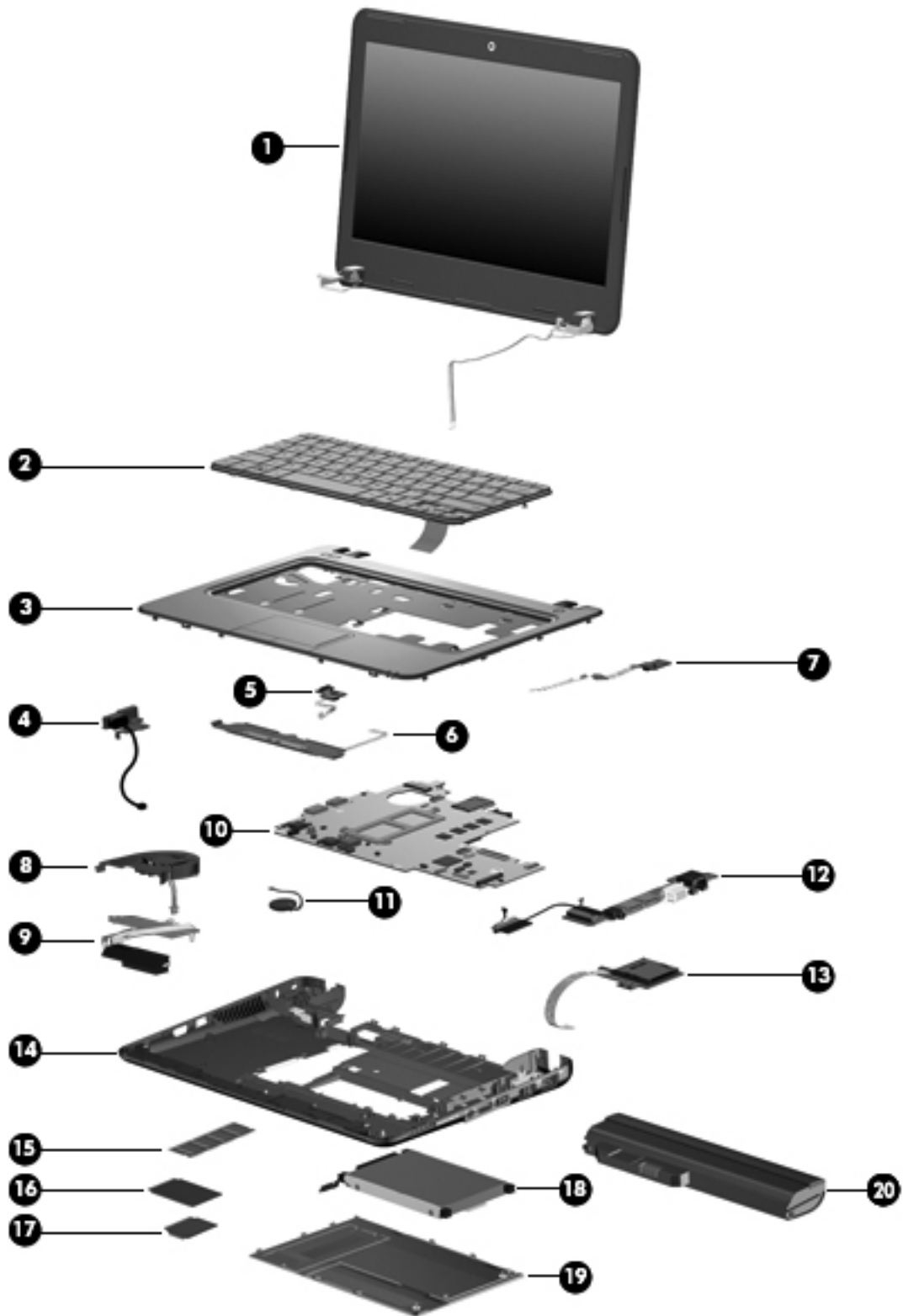

Item	Description	Spare part number
(1)	11.6-in (1366 × 768) HD, BrightView, LED display assembly (includes webcam, microphone, 2 WLAN antenna transceivers and cables, nameplate, and logo):	
	Display assembly with 2 WWAN antennas for use with the HP Mini	580006-001
	Display assembly for use with the HP Mini	580007-001
	Display assembly with 2 WWAN antennas for use with the Compaq Mini	580011-001
	Display assembly with 2 WWAN antenna for use with the black-colored HP Pavilion	588689-001
	Display assembly with 2 WWAN antenna for use with the white-colored HP Pavilion	588690-001
	 See “Display assembly subcomponents” on page 3-9 for display assembly internal component spare part information.	
(2)	Keyboard (includes keyboard cable):	
	For use in Belgium	580030-A41
	For use in the Czech Republic	580030-221
	For use in Demark	580030-DH1
	For use in France	580030-051
	For use with the HP Mini and Compaq Mini in French Canada	580030-121
	For use in Germany	580030-041
	For use in Greece	580030-DJ1
	For use in Hungary	580030-211
	For use in Israel	580030-BB1
	For use in Italy	580030-061
	For use in Japan	580030-291
	For use in the Netherlands	580030-B31
	For use in Portugal	580030-131
	For use in Russia	580030-251
	For use in Saudi Arabia	580030-171
	For use in South Korea	580030-AD1
	For use in Spain	580030-071
	For use in Switzerland	580030-BG1
	For use in Taiwan	580030-AB1
	For use in Thailand	580030-281
	For use in Turkey	580030-141
	For use in the United Kingdom	580030-031
	For use in the United States	580030-001
(3)	Top cover (includes TouchPad button board and cable, and TouchPad board and cable)	580057-001

(Continued)

Item	Description	Spare part number
(4)	Power connector (includes cable)	591851-001
(5)	Power button board (includes cable)	580058-001
(6)	Speakers (include cables)	580064-001
(7)	Wireless button board (includes cable)	580060-001
(8)	Fan (includes cable)	580061-001
(9)	Heat sink assembly (includes replacement thermal material):	
	For use with the HP Mini and Compaq Mini	580059-001
	For use with the HP Pavilion	581758-001
(10)	System board (includes processor, 1024-MB base memory, and replacement thermal material):	
	Includes Intel Atom N280 1.66-GHz processor, 512-KB Level 2 cache, 667-MHz front-side bus (FSB) for use with the HP Mini and Compaq Mini	580000-001
	Includes Intel Atom N270 1.6-GHz processor, 512-KB Level 2 cache, 533-MHz front-side bus (FSB) for use with the HP Mini and Compaq Mini	579999-001
	Includes Intel Pentium 1.3-GHz processor, 2048-KB Level 2 cache, 800-MHz FSB for use with the HP Pavilion	581751-001
	Includes Intel Pentium 1.2-GHz processor, 1024-KB Level 2 cache, 800-MHz FSB for use with the HP Pavilion	581750-001
(11)	RTC battery	580055-001
(12)	Multi board (includes USB and RJ-45 ports, and cable)	580066-001
	Multi board for use with the HP Pavilion (includes USB and RJ-45 ports, and cable)	591994-001
(13)	Digital media assembly (includes cable)	580065-001
(14)	Base enclosure (includes 5 rubber device feet)	580054-001
(15)	Expansion memory module (1333-MHz, DDR3):	
	4096-MB for use with the HP Pavilion	581754-001
	4096-MB for use with the HP Pavilion in systems that include a WWAN module	581754-002
	2048-MB	580017-001
	2048-MB, for use with the HP Mini and Compaq Mini in systems that include a WWAN module	580017-002
	2048-MB, for use with the HP Pavilion in systems that include a WWAN module	591374-001
	1024-MB	580016-001
	1024-MB, for use with the HP Mini and Compaq Mini in systems that include a WWAN module	580016-002
	1024-MB, for use with the HP Pavilion in systems that include a WWAN module	591373-001
(16)	WWAN module:	
	HSPA EV-DO WWAN module for use in all countries and regions except the People's Republic of China	483377-002
	HSPA EV-DO WWAN module for use in the People's Republic of China	483377-003
	UNDP HSPA EV-DO WWAN mini module	531993-001

(Continued)

Item	Description	Spare part number
(17)	WLAN module:	
	802.11b/g/n WLAN module:	
	■ Broadcom 4322AGN 802.11b/g/n WLAN module for use in Canada, the Cayman Islands, Guam, Puerto Rico, the United States, and the U.S. Virgin Islands	518436-001
	■ Broadcom 4322AGN 802.11b/g/n WLAN module for use in Afghanistan, Albania, Algeria, Andorra, Angola, Antigua and Barbuda, Argentina, Armenia, Aruba, Australia, Austria, Azerbaijan, the Bahamas, Bahrain, Bangladesh, Barbados, Belarus, Belgium, Belize, Benin, Bermuda, Bhutan, Bolivia, Bosnia and Herzegovina, Botswana, Brazil, the British Virgin Islands, Brunei, Bulgaria, Burkina Faso, Burundi, Cambodia, Cameroon, Cape Verde, the Central African Republic, Chad, Colombia, Comoros, the Congo, Costa Rica, Croatia, Cyprus, the Czech Republic, Denmark, Djibouti, Dominica, the Dominican Republic, East Timor, Ecuador, Egypt, El Salvador, Equatorial Guinea, Eritrea, Estonia, Ethiopia, Fiji, Finland, France, French Guiana, Gabon, Gambia, Georgia, Germany, Ghana, Gibraltar, Greece, Grenada, Guadeloupe, Guatemala, Guinea, Guinea-Bissau, Guyana, Haiti, Honduras, Hong Kong, Hungary, Iceland, India, Indonesia, Ireland, Israel, Italy, the Ivory Coast, Jamaica, Japan, Jordan, Kazakhstan, Kenya, Kiribati, Kuwait, Kyrgyzstan, Laos, Latvia, Lebanon, Lesotho, Liberia, Liechtenstein, Lithuania, Luxembourg, Macedonia, Madagascar, Malawi, Malaysia, the Maldives, Mali, Malta, the Marshall Islands, Martinique, Mauritania, Mauritius, Mexico, Micronesia, Monaco, Mongolia, Montenegro, Morocco, Mozambique, Namibia, Nauru, Nepal, the Nether Antilles, the Netherlands, New Zealand, Nicaragua, Niger, Nigeria, Norway, Oman, Pakistan, Palau, Panama, Papua New Guinea, Paraguay, the People's Republic of China, Peru, the Philippines, Poland, Portugal, Qatar, the Republic of Moldova, Romania, Russia, Rwanda, Samoa, San Marino, Sao Tome and Principe, Saudi Arabia, Senegal, Serbia, the Seychelles, Sierra Leone, Singapore, Slovakia, Slovenia, the Solomon Islands, Somalia, South Africa, South Korea, Spain, Sri Lanka, St. Kitts and Nevis, St. Lucia, St. Vincent and the Grenadines, Suriname, Swaziland, Sweden, Switzerland, Syria, Taiwan, Tajikistan, Tanzania, Thailand, Togo, Tonga, Trinidad and Tobago, Tunisia, Turkey, Turkmenistan, Tuvalu, Uganda, Ukraine, the United Arab Emirates, the United Kingdom, Uruguay, Uzbekistan, Vanuatu, Venezuela, Vietnam, Yemen, Zaire, Zambia, and Zimbabwe	518436-002
	Intel WiFi Link 5100 802.11b/g WLAN module for use in Pakistan, Russia, and the Ukraine	482957-001

(Continued)

Item	Description	Spare part number
	802.11a/b/g/n WLAN module:	
■	Broadcom 4322AGN 802.11a/b/g/n WLAN module for use in Afghanistan, Albania, Algeria, Andorra, Angola, Antigua and Barbuda, Argentina, Armenia, Aruba, Australia, Austria, Azerbaijan, the Bahamas, Bahrain, Bangladesh, Barbados, Belarus, Belgium, Belize, Benin, Bermuda, Bhutan, Bolivia, Bosnia and Herzegovina, Botswana, Brazil, the British Virgin Islands, Brunei, Bulgaria, Burkina Faso, Burundi, Cambodia, Cameroon, Cape Verde, the Central African Republic, Chad, Colombia, Comoros, the Congo, Costa Rica, Croatia, Cyprus, the Czech Republic, Denmark, Djibouti, Dominica, the Dominican Republic, East Timor, Ecuador, Egypt, El Salvador, Equatorial Guinea, Eritrea, Estonia, Ethiopia, Fiji, Finland, France, French Guiana, Gabon, Gambia, Georgia, Germany, Ghana, Gibraltar, Greece, Grenada, Guadeloupe, Guatemala, Guinea, Guinea-Bissau, Guyana, Haiti, Honduras, Hong Kong, Hungary, Iceland, India, Indonesia, Ireland, Israel, Italy, the Ivory Coast, Jamaica, Japan, Jordan, Kazakhstan, Kenya, Kiribati, Kuwait, Kyrgyzstan, Laos, Latvia, Lebanon, Lesotho, Liberia, Liechtenstein, Lithuania, Luxembourg, Macedonia, Madagascar, Malawi, Malaysia, the Maldives, Mali, Malta, the Marshall Islands, Martinique, Mauritania, Mauritius, Mexico, Micronesia, Monaco, Mongolia, Montenegro, Morocco, Mozambique, Namibia, Nauru, Nepal, the Nether Antilles, the Netherlands, New Zealand, Nicaragua, Niger, Nigeria, Norway, Oman, Pakistan, Palau, Panama, Papua New Guinea, Paraguay, the People's Republic of China, Peru, the Philippines, Poland, Portugal, Qatar, the Republic of Moldova, Romania, Russia, Rwanda, Samoa, San Marino, Sao Tome and Principe, Saudi Arabia, Senegal, Serbia, the Seychelles, Sierra Leone, Singapore, Slovakia, Slovenia, the Solomon Islands, Somalia, South Africa, South Korea, Spain, Sri Lanka, St. Kitts and Nevis, St. Lucia, St. Vincent and the Grenadines, Suriname, Swaziland, Sweden, Switzerland, Syria, Taiwan, Tajikistan, Tanzania, Thailand, Togo, Tonga, Trinidad and Tobago, Tunisia, Turkey, Turkmenistan, Tuvalu, Uganda, Ukraine, the United Arab Emirates, the United Kingdom, Uruguay, Uzbekistan, Vanuatu, Venezuela, Vietnam, Yemen, Zaire, Zambia, and Zimbabwe	518434-002

(Continued)

Item	Description	Spare part number
	802.11b/g WLAN module:	
	■ WLAN/Bluetooth combo card	575920-001
	■ Broadcom 4312G 802.11b/g WLAN module in Canada, the Cayman Islands, Guam, Puerto Rico, the United States, and the U.S. Virgin Islands	504593-003
	■ Broadcom 4312G 802.11b/g WLAN module for use in Afghanistan, Albania, Algeria, Andorra, Angola, Antigua and Barbuda, Argentina, Armenia, Aruba, Australia, Austria, Azerbaijan, the Bahamas, Bahrain, Bangladesh, Barbados, Belarus, Belgium, Belize, Benin, Bermuda, Bhutan, Bolivia, Bosnia and Herzegovina, Botswana, Brazil, the British Virgin Islands, Brunei, Bulgaria, Burkina Faso, Burundi, Cambodia, Cameroon, Cape Verde, the Central African Republic, Chad, Colombia, Comoros, the Congo, Costa Rica, Croatia, Cyprus, the Czech Republic, Denmark, Djibouti, Dominica, the Dominican Republic, East Timor, Ecuador, Egypt, El Salvador, Equatorial Guinea, Eritrea, Estonia, Ethiopia, Fiji, Finland, France, French Guiana, Gabon, Gambia, Georgia, Germany, Ghana, Gibraltar, Greece, Grenada, Guadeloupe, Guatemala, Guinea, Guinea-Bissau, Guyana, Haiti, Honduras, Hong Kong, Hungary, Iceland, India, Indonesia, Ireland, Israel, Italy, the Ivory Coast, Jamaica, Japan, Jordan, Kazakhstan, Kenya, Kiribati, Kuwait, Kyrgyzstan, Laos, Latvia, Lebanon, Lesotho, Liberia, Liechtenstein, Lithuania, Luxembourg, Macedonia, Madagascar, Malawi, Malaysia, the Maldives, Mali, Malta, the Marshall Islands, Martinique, Mauritania, Mauritius, Mexico, Micronesia, Monaco, Mongolia, Montenegro, Morocco, Mozambique, Namibia, Nauru, Nepal, the Nether Antilles, the Netherlands, New Zealand, Nicaragua, Niger, Nigeria, Norway, Oman, Pakistan, Palau, Panama, Papua New Guinea, Paraguay, the People's Republic of China, Peru, the Philippines, Poland, Portugal, Qatar, the Republic of Moldova, Romania, Russia, Rwanda, Samoa, San Marino, Sao Tome and Principe, Saudi Arabia, Senegal, Serbia, the Seychelles, Sierra Leone, Singapore, Slovakia, Slovenia, the Solomon Islands, Somalia, South Africa, South Korea, Spain, Sri Lanka, St. Kitts and Nevis, St. Lucia, St. Vincent and the Grenadines, Suriname, Swaziland, Sweden, Switzerland, Syria, Taiwan, Tajikistan, Tanzania, Thailand, Togo, Tonga, Trinidad and Tobago, Tunisia, Turkey, Turkmenistan, Tuvalu, Uganda, Ukraine, the United Arab Emirates, the United Kingdom, Uruguay, Uzbekistan, Vanuatu, Venezuela, Vietnam, Yemen, Zaire, Zambia, and Zimbabwe	504593-004

(Continued)

Item	Description	Spare part number
(18)	Hard drive (includes hard drive connector and hard drive bracket):	
	500-GB, 5400-rpm for use with the HP Pavilion	584512-001
	500-GB, 5400-rpm, for use with the HP Pavilion in systems that include a WWAN module	591372-001
	320-GB, 5400-rpm	580020-001
	320-GB, 5400-rpm, for use with the HP Mini and Compaq Mini in systems that include a WWAN module	580020-002
	320-GB, 5400-rpm, for use with the HP Pavilion in systems that include a WWAN module	591371-001
	250-GB, 5400-rpm	580019-001
	250-GB, 5400-rpm, for use with the HP Mini and Compaq Mini in systems that include a WWAN module	580019-002
	250-GB, 5400-rpm, for use with the HP Pavilion in systems that include a WWAN module	591370-001
	160-GB, 7200-rpm	591250-001
	160-GB, 5400-rpm	580018-001
	160-GB, 5400-rpm, for use with the HP Mini and Compaq Mini in systems that include a WWAN module	580018-002
	160-GB, 5400-rpm, for use with the HP Pavilion in systems that include a WWAN module	591369-001
	80-GB solid state drive (SSD)	584513-001
	Hard Drive Hardware Kit (not illustrated, includes hard drive connector and hard drive bracket)	580024-001
	Solid State Drive Hardware Kit (not illustrated)	580023-001
(19)	Accessory compartment cover	580056-001
(20)	6-cell, 2.55-Ah (55-Wh) Li-ion battery	580029-001

Display assembly subcomponents

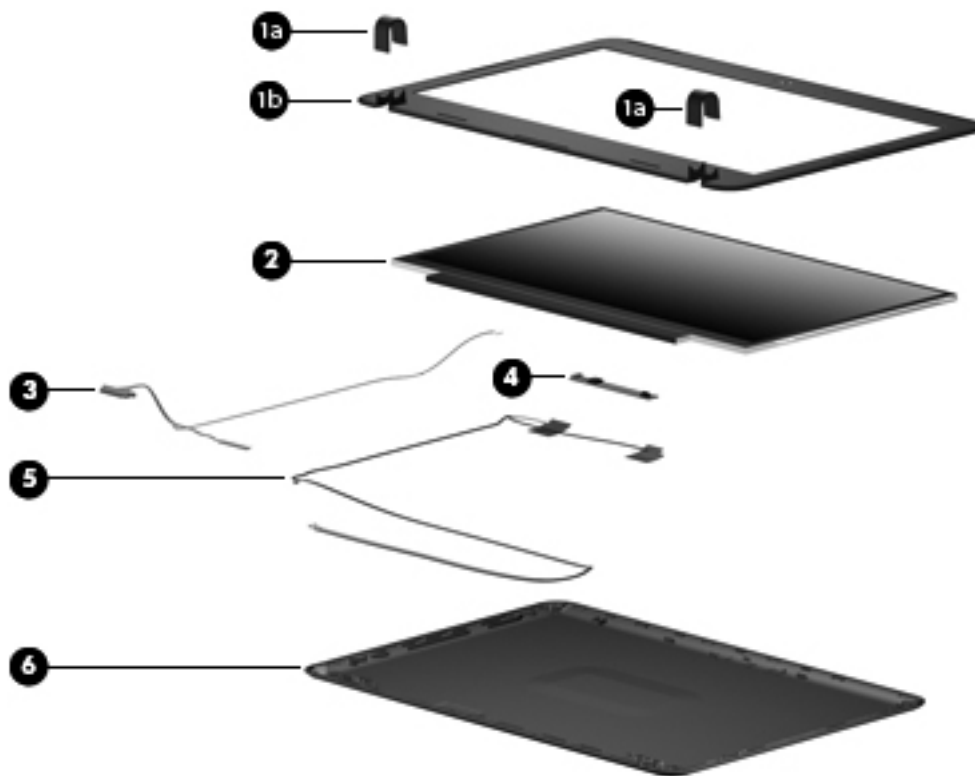

Item	Description	Spare part number
	Display bezel (includes hinge covers):	
(1a)	Hinge covers	
(1b)	Bezel	
	■ For use only with the HP Mini	580010-001
	■ For use only with the Compaq Mini	580015-001
	■ For use only with the HP Pavilion	587312-001
(2)	Display panel	580001-001
(3)	Display panel/webcam/microphone cable	580003-001
(4)	Webcam module	580004-001
(5)	Wireless antenna cables	580005-001
(6)	Display enclosure:	
	For use with the HP Mini	580009-001
	For use with the HP Mini that includes WWAN	580008-001
	For use with the Compaq Mini	580013-001

Miscellaneous parts

Description	Spare part number
65-W AC adapter	417220-001
External USB optical drive:	
Blu-ray ROM with LightScribe DVD±R/RW and CD-RW SuperMulti Double-Layer Drive	580026-001
DVD±RW and CD-RW SuperMulti Double-Layer Drive with LightScribe	580025-001
HP Mini Messenger Carrying Case for use with the HP Mini and Compaq Mini	588688-001
Mini Sleeve for use with the HP Pavilion	588589-001
Power cord:	
For use with the HP Mini and Compaq Mini in Argentina	490371-D01
For use in Australia	490371-011
For use with the HP Mini and Compaq Mini in Brazil	490371-201
For use in Denmark	490371-081
For use in Europe, the Middle East, and Africa	490371-021
For use in India	490371-D61
For use in Israel	490371-BB1
For use in Italy	490371-061
For use in Japan	490371-291
For use in South Africa	490371-AR1
For use in South Korea	490371-AD1
For use in Switzerland	490371-111
For use in Taiwan	490371-AB1
For use in the People's Republic of China	490371-AA1
For use in the United Kingdom and Singapore	490371-031
For use in the United States	490371-001
Rubber Feet Kit (includes 5 rubber device feet and 8 display bezel screw covers)	580062-001
Screw Kit	580063-001

Sequential part number listing

Spare part number	Description
417220-001	65-W AC adapter
482957-001	Intel WiFi Link 5100 802.11b/g WLAN module for use with the HP Mini and Compaq Mini in Pakistan, Russia, and the Ukraine
483377-002	HSPA EV-DO WWAN module for use with the HP Mini and Compaq Mini in all countries and regions except the People's Republic of China
490371-001	Power cord for use in the United States
490371-011	Power cord for use in Australia
490371-021	Power cord for use in Europe, the Middle East, and Africa
490371-031	Power cord for use in the United Kingdom and Singapore
490371-061	Power cord for use in Italy
490371-081	Power cord for use in Denmark
490371-111	Power cord for use in Switzerland
490371-201	Power cord for use with the HP Mini and Compaq Mini in Brazil
490371-291	Power cord for use in Japan
490371-AA1	Power cord for use in the People's Republic of China
490371-AB1	Power cord for use in Taiwan
490371-AD1	Power cord for use in South Korea
490371-AR1	Power cord for use in South Africa
490371-BB1	Power cord for use in Israel
490371-D01	Power cord for use with the HP Mini and Compaq Mini in Argentina
490371-D61	Power cord for use in India
504593-003	Broadcom 4312G 802.11b/g WLAN module for use with the HP Mini and Compaq Mini in Canada, the Cayman Islands, Guam, Puerto Rico, the United States, and the U.S. Virgin Islands

(Continued)

Spare part number	Description
504593-004	Broadcom 4312G 802.11b/g WLAN module for use in Afghanistan, Albania, Algeria, Andorra, Angola, Antigua and Barbuda, Argentina, Armenia, Aruba, Australia, Austria, Azerbaijan, the Bahamas, Bahrain, Bangladesh, Barbados, Belarus, Belgium, Belize, Benin, Bermuda, Bhutan, Bolivia, Bosnia and Herzegovina, Botswana, Brazil, the British Virgin Islands, Brunei, Bulgaria, Burkina Faso, Burundi, Cambodia, Cameroon, Cape Verde, the Central African Republic, Chad, Colombia, Comoros, the Congo, Costa Rica, Croatia, Cyprus, the Czech Republic, Denmark, Djibouti, Dominica, the Dominican Republic, East Timor, Ecuador, Egypt, El Salvador, Equatorial Guinea, Eritrea, Estonia, Ethiopia, Fiji, Finland, France, French Guiana, Gabon, Gambia, Georgia, Germany, Ghana, Gibraltar, Greece, Grenada, Guadeloupe, Guatemala, Guinea, Guinea-Bissau, Guyana, Haiti, Honduras, Hong Kong, Hungary, Iceland, India, Indonesia, Ireland, Israel, Italy, the Ivory Coast, Jamaica, Japan, Jordan, Kazakhstan, Kenya, Kiribati, Kuwait, Kyrgyzstan, Laos, Latvia, Lebanon, Lesotho, Liberia, Liechtenstein, Lithuania, Luxembourg, Macedonia, Madagascar, Malawi, Malaysia, the Maldives, Mali, Malta, the Marshall Islands, Martinique, Mauritania, Mauritius, Mexico, Micronesia, Monaco, Mongolia, Montenegro, Morocco, Mozambique, Namibia, Nauru, Nepal, the Nether Antilles, the Netherlands, New Zealand, Nicaragua, Niger, Nigeria, Norway, Oman, Pakistan, Palau, Panama, Papua New Guinea, Paraguay, the People's Republic of China, Peru, the Philippines, Poland, Portugal, Qatar, the Republic of Moldova, Romania, Russia, Rwanda, Samoa, San Marino, Sao Tome and Principe, Saudi Arabia, Senegal, Serbia, the Seychelles, Sierra Leone, Singapore, Slovakia, Slovenia, the Solomon Islands, Somalia, South Africa, South Korea, Spain, Sri Lanka, St. Kitts and Nevis, St. Lucia, St. Vincent and the Grenadines, Suriname, Swaziland, Sweden, Switzerland, Syria, Taiwan, Tajikistan, Tanzania, Thailand, Togo, Tonga, Trinidad and Tobago, Tunisia, Turkey, Turkmenistan, Tuvalu, Uganda, Ukraine, the United Arab Emirates, the United Kingdom, Uruguay, Uzbekistan, Vanuatu, Venezuela, Vietnam, Yemen, Zaire, Zambia, and Zimbabwe
518434-001	Broadcom 4322AGN 802.11a/b/g/n WLAN module for use in Canada, the Cayman Islands, Guam, Puerto Rico, the United States, and the U.S. Virgin Islands
518434-002	Broadcom 4322AGN 802.11a/b/g/n WLAN module for use in Afghanistan, Albania, Algeria, Andorra, Angola, Antigua and Barbuda, Argentina, Armenia, Aruba, Australia, Austria, Azerbaijan, the Bahamas, Bahrain, Bangladesh, Barbados, Belarus, Belgium, Belize, Benin, Bermuda, Bhutan, Bolivia, Bosnia and Herzegovina, Botswana, Brazil, the British Virgin Islands, Brunei, Bulgaria, Burkina Faso, Burundi, Cambodia, Cameroon, Cape Verde, the Central African Republic, Chad, Colombia, Comoros, the Congo, Costa Rica, Croatia, Cyprus, the Czech Republic, Denmark, Djibouti, Dominica, the Dominican Republic, East Timor, Ecuador, Egypt, El Salvador, Equatorial Guinea, Eritrea, Estonia, Ethiopia, Fiji, Finland, France, French Guiana, Gabon, Gambia, Georgia, Germany, Ghana, Gibraltar, Greece, Grenada, Guadeloupe, Guatemala, Guinea, Guinea-Bissau, Guyana, Haiti, Honduras, Hong Kong, Hungary, Iceland, India, Indonesia, Ireland, Israel, Italy, the Ivory Coast, Jamaica, Japan, Jordan, Kazakhstan, Kenya, Kiribati, Kuwait, Kyrgyzstan, Laos, Latvia, Lebanon, Lesotho, Liberia, Liechtenstein, Lithuania, Luxembourg, Macedonia, Madagascar, Malawi, Malaysia, the Maldives, Mali, Malta, the Marshall Islands, Martinique, Mauritania, Mauritius, Mexico, Micronesia, Monaco, Mongolia, Montenegro, Morocco, Mozambique, Namibia, Nauru, Nepal, the Nether Antilles, the Netherlands, New Zealand, Nicaragua, Niger, Nigeria, Norway, Oman, Pakistan, Palau, Panama, Papua New Guinea, Paraguay, the People's Republic of China, Peru, the Philippines, Poland, Portugal, Qatar, the Republic of Moldova, Romania, Russia, Rwanda, Samoa, San Marino, Sao Tome and Principe, Saudi Arabia, Senegal, Serbia, the Seychelles, Sierra Leone, Singapore, Slovakia, Slovenia, the Solomon Islands, Somalia, South Africa, South Korea, Spain, Sri Lanka, St. Kitts and Nevis, St. Lucia, St. Vincent and the Grenadines, Suriname, Swaziland, Sweden, Switzerland, Syria, Taiwan, Tajikistan, Tanzania, Thailand, Togo, Tonga, Trinidad and Tobago, Tunisia, Turkey, Turkmenistan, Tuvalu, Uganda, Ukraine, the United Arab Emirates, the United Kingdom, Uruguay, Uzbekistan, Vanuatu, Venezuela, Vietnam, Yemen, Zaire, Zambia, and Zimbabwe

(Continued)

Spare part number	Description
518436-001	Broadcom 4322AGN 802.11b/g/n WLAN module for use in Canada, the Cayman Islands, Guam, Puerto Rico, the United States, and the U.S. Virgin Islands
518436-002	Broadcom 4322AGN 802.11b/g/n WLAN module for use in Afghanistan, Albania, Algeria, Andorra, Angola, Antigua and Barbuda, Argentina, Armenia, Aruba, Australia, Austria, Azerbaijan, the Bahamas, Bahrain, Bangladesh, Barbados, Belarus, Belgium, Belize, Benin, Bermuda, Bhutan, Bolivia, Bosnia and Herzegovina, Botswana, Brazil, the British Virgin Islands, Brunei, Bulgaria, Burkina Faso, Burundi, Cambodia, Cameroon, Cape Verde, the Central African Republic, Chad, Colombia, Comoros, the Congo, Costa Rica, Croatia, Cyprus, the Czech Republic, Denmark, Djibouti, Dominica, the Dominican Republic, East Timor, Ecuador, Egypt, El Salvador, Equatorial Guinea, Eritrea, Estonia, Ethiopia, Fiji, Finland, France, French Guiana, Gabon, Gambia, Georgia, Germany, Ghana, Gibraltar, Greece, Grenada, Guadeloupe, Guatemala, Guinea, Guinea-Bissau, Guyana, Haiti, Honduras, Hong Kong, Hungary, Iceland, India, Indonesia, Ireland, Israel, Italy, the Ivory Coast, Jamaica, Japan, Jordan, Kazakhstan, Kenya, Kiribati, Kuwait, Kyrgyzstan, Laos, Latvia, Lebanon, Lesotho, Liberia, Liechtenstein, Lithuania, Luxembourg, Macedonia, Madagascar, Malawi, Malaysia, the Maldives, Mali, Malta, the Marshall Islands, Martinique, Mauritania, Mauritius, Mexico, Micronesia, Monaco, Mongolia, Montenegro, Morocco, Mozambique, Namibia, Nauru, Nepal, the Nether Antilles, the Netherlands, New Zealand, Nicaragua, Niger, Nigeria, Norway, Oman, Pakistan, Palau, Panama, Papua New Guinea, Paraguay, the People's Republic of China, Peru, the Philippines, Poland, Portugal, Qatar, the Republic of Moldova, Romania, Russia, Rwanda, Samoa, San Marino, Sao Tome and Principe, Saudi Arabia, Senegal, Serbia, the Seychelles, Sierra Leone, Singapore, Slovakia, Slovenia, the Solomon Islands, Somalia, South Africa, South Korea, Spain, Sri Lanka, St. Kitts and Nevis, St. Lucia, St. Vincent and the Grenadines, Suriname, Swaziland, Sweden, Switzerland, Syria, Taiwan, Tajikistan, Tanzania, Thailand, Togo, Tonga, Trinidad and Tobago, Tunisia, Turkey, Turkmenistan, Tuvalu, Uganda, Ukraine, the United Arab Emirates, the United Kingdom, Uruguay, Uzbekistan, Vanuatu, Venezuela, Vietnam, Yemen, Zaire, Zambia, and Zimbabwe
531993-001	UNDP HSPA EV-DO WWAN mini module
537921-001	Bluetooth card for use with the HP Pavilion
575920-001	WLAN/Bluetooth combo card
579999-001	System board for use with the HP Mini and Compaq Mini (includes Intel Atom N270 1.6-GHz processor, 512-KB Level 2 cache, 533-MHz FSB, 1024-MB base memory, and replacement thermal material)
580000-001	System board for use with the HP Mini and Compaq Mini (includes Intel Atom N280 1.66-GHz processor, 512-KB Level 2 cache, 667-MHz FSB, 1024-MB base memory, and replacement thermal material)
580001-001	Display panel
580003-001	Display panel cable
580004-001	Webcam module
580005-001	Wireless antenna cables
580006-001	11.6-in (1366 × 768) HD, BrightView, LED display assembly with 2 WWAN antennas for use with the HP Mini (includes webcam, microphone, 2 WLAN antenna transceivers and cables, nameplate, and logo)
580007-001	11.6-in (1366 × 768) HD, BrightView, LED display assembly for use with the HP Mini (includes webcam, microphone, 2 WLAN antenna transceivers and cables, nameplate, and logo)
580008-001	Display enclosure for use with the HP Mini and HP Pavilion that include WWAN
580009-001	Display enclosure for use with the HP Mini and HP Pavilion
580010-001	Display bezel for use only with the HP Mini (includes hinge covers)
580011-001	11.6-in (1366 × 768) HD, BrightView, LED display assembly with 2 WWAN antennas for use with the Compaq Mini (includes webcam, microphone, 2 WLAN antenna transceivers and cables, nameplate, and logo)

(Continued)

Spare part number	Description
580013-001	Display enclosure for use with the Compaq Mini
580015-001	Display bezel for use only with the Compaq Mini (includes hinge covers)
580016-001	1024-MB expansion memory module (1333-MHz, DDR3)
580016-002	1024-MB expansion memory module (1333-MHz, DDR2), for use with the HP Mini and Compaq Mini with systems that include a WWAN module
580017-001	2048-MB expansion memory module (1333-MHz, DDR3)
580017-002	2048-MB expansion memory module (1333-MHz, DDR2), for use with the HP Mini and Compaq Mini with systems that include a WWAN module
580018-001	160-GB, 5400-rpm hard drive (includes hard drive connector and hard drive bracket)
580018-002	160-GB, 5400-rpm hard drive, for use with the HP Mini and Compaq Mini in systems that include a WWAN module (includes hard drive connector and hard drive bracket)
580019-001	250-GB, 5400-rpm hard drive (includes hard drive connector and hard drive bracket)
580019-002	250-GB, 5400-rpm hard drive, for use with the HP Mini and Compaq Mini in systems that include a WWAN module (includes hard drive connector and hard drive bracket)
580020-001	320-GB, 5400-rpm hard drive (includes hard drive connector and hard drive bracket)
580020-002	320-GB, 5400-rpm hard drive, for use with the HP Mini and Compaq Mini in systems that include a WWAN module (includes hard drive connector and hard drive bracket)
580023-001	Solid State Drive Hardware Kit
580024-001	Hard Drive Hardware Kit (includes hard drive connector and hard drive bracket)
580025-001	DVD±RW and CD-RW SuperMulti Double-Layer Drive with LightScribe external USB optical drive
580026-001	Blu-ray ROM DVD±R/RW and CD-RW SuperMulti Double-Layer Drive with LightScribe external USB optical drive
580029-001	6-cell, 2.55-Ah (55-Wh) Li-ion battery
580030-001	Keyboard for use in the United States (includes keyboard cable)
580030-031	Keyboard for use in the United Kingdom (includes keyboard cable)
580030-041	Keyboard for use in Germany (includes keyboard cable)
580030-051	Keyboard for use in France (includes keyboard cable)
580030-061	Keyboard for use in Italy (includes keyboard cable)
580030-071	Keyboard for use in Spain (includes keyboard cable)
580030-121	Keyboard for use with the HP Mini and Compaq Mini in French Canada (includes keyboard cable)
580030-131	Keyboard for use in Portugal (includes keyboard cable)
580030-141	Keyboard for use in Turkey (includes keyboard cable)
580030-171	Keyboard for use in Saudi Arabia (includes keyboard cable)
580030-211	Keyboard for use in Hungary (includes keyboard cable)
580030-221	Keyboard for use in the Czech Republic (includes keyboard cable)
580030-251	Keyboard for use in Russia (includes keyboard cable)
580030-281	Keyboard for use in Thailand (includes keyboard cable)
580030-291	Keyboard for use in Japan (includes keyboard cable)
580030-AB1	Keyboard for use in Taiwan (includes keyboard cable)
580030-AD1	Keyboard for use in South Korea (includes keyboard cable)

(Continued)

Spare part number	Description
580030-A41	Keyboard for use in Belgium (includes keyboard cable)
580030-B31	Keyboard for use in the Netherlands (includes keyboard cable)
580030-BB1	Keyboard for use in Israel (includes keyboard cable)
580030-BG1	Keyboard for use in Switzerland (includes keyboard cable)
580030-DH1	Keyboard for use in Demark (includes keyboard cable)
580030-DJ1	Keyboard for use in Greece (includes keyboard cable)
580054-001	Base enclosure (includes 5 rubber device feet)
580055-001	RTC battery
580056-001	Accessory compartment cover
580057-001	Top cover (includes TouchPad button board and cable, and TouchPad board and cable)
580058-001	Power button board (includes cable)
580059-001	Heat sink assembly for use with the HP Mini and Compaq Mini (includes replacement thermal material)
580060-001	Wireless button board (includes cable)
580061-001	Fan (includes cable)
580062-001	Rubber Feet Kit (includes 5 rubber device feet and 8 display bezel screw covers)
580063-001	Screw Kit
580064-001	Speakers (include cables)
580065-001	Digital media assembly (includes cable)
580066-001	Multi board (includes USB and RJ-45 ports, and cable)
581750-001	System board for use with the HP Pavilion (includes Intel Pentium 1.2-GHz processor, 1024-KB Level 2 cache, 800-MHz FSB, 1024-MB base memory, and replacement thermal material)
581751-001	System board for use with the HP Pavilion (includes Intel Pentium 1.3-GHz processor, 2048-KB Level 2 cache, 800-MHz FSB, 1024-MB base memory, and replacement thermal material)
581754-001	4096-MB expansion memory module (1333-MHz, DDR3), for use with the HP Pavilion
581754-002	4096-MB expansion memory module (1333-MHz, DDR3), for use with the HP Pavilion in systems that include a WWAN module
581758-001	Heat sink assembly for use with the HP Pavilion (includes replacement thermal material)
584512-001	500-GB, 5400-rpm hard drive for use with HP Pavilion
584513-001	80-GB solid state drive (SSD)
587312-001	Display bezel for use only with the HP Pavilion
588589-001	12.1-in Mini sleeve for use with HP Pavilion
588688-001	HP Mini Messenger Carrying Case
588689-001	11.6-in (1366 × 768) HD, BrightView, white-colored, LED display assembly with 2 WWAN antennas for use with the HP Pavilion (includes webcam, microphone, 2 WLAN antenna transceivers and cables, nameplate, and logo)
588690-001	11.6-in (1366 × 768) HD, BrightView, black-colored, LED display assembly with 2 WWAN antennas for use with the HP Pavilion (includes webcam, microphone, 2 WLAN antenna transceivers and cables, nameplate, and logo)
591250-001	160-GB, 7200-rpm hard drive
591369-001	160-GB, 5400-rpm hard drive for use with the HP Pavilion in systems that include a WWAN module

(Continued)

Spare part number	Description
591370-001	250-GB, 5400-rpm hard drive for use with the HP Pavilion in systems that include a WWAN module
591371-001	320-GB, 5400-rpm hard drive for use with the HP Pavilion in systems that include a WWAN module
591372-001	500-GB, 5400-rpm hard drive for use with the HP Pavilion in systems that include a WWAN module
591373-001	1024-MB expansion memory module (1333-MHz, DDR3), for use with the HP Pavilion in systems that include a WWAN module
591374-001	2048-MB expansion memory module (1333-MHz, DDR3), for use with the HP Pavilion in systems that include a WWAN module
591851-001	Power connector (includes cable)
591994-001	Multi board for use with the HP Pavilion (includes USB and RJ-45 ports, and cable)

Removal and replacement procedures

Preliminary replacement requirements

Tools required

You will need the following tools to complete the removal and replacement procedures:

- Flat-bladed screwdriver
- Phillips P0 screwdriver
- Phillips P1 screwdriver
- Torx T8 screwdriver

Service considerations

The following sections include some of the considerations that you must keep in mind during disassembly and assembly procedures.



As you remove each subassembly from the computer, place the subassembly (and all accompanying screws) away from the work area to prevent damage.

Plastic parts



CAUTION: Using excessive force during disassembly and reassembly can damage plastic parts. Use care when handling the plastic parts. Apply pressure only at the points designated in the maintenance instructions.

Cables and connectors



CAUTION: When servicing the computer, be sure that cables are placed in their proper locations during the reassembly process. Improper cable placement can damage the computer.

Cables must be handled with extreme care to avoid damage. Apply only the tension required to unseat or seat the cables during removal and insertion. Handle cables by the connector whenever possible. In all cases, avoid bending, twisting, or tearing cables. Be sure that cables are routed in such a way that they cannot be caught or snagged by parts being removed or replaced. Handle flex cables with extreme care; these cables tear easily.

Drive handling

 **CAUTION:** Drives are fragile components that must be handled with care. To prevent damage to the computer, damage to a drive, or loss of information, observe these precautions:

- Before removing or inserting a hard drive, shut down the computer. If you are unsure whether the computer is off or in Hibernation, turn the computer on, and then shut it down through the operating system.
 - Before handling a drive, be sure that you are discharged of static electricity. While handling a drive, avoid touching the connector.
 - Before removing a diskette drive or optical drive, be sure that a diskette or disc is not in the drive and be sure that the optical drive tray is closed.
 - Handle drives on surfaces covered with at least one inch of shock-proof foam.
 - Avoid dropping drives from any height onto any surface.
 - After removing a hard drive, an optical drive, or a diskette drive, place it in a static-proof bag.
 - Avoid exposing a hard drive to products that have magnetic fields, such as monitors or speakers.
 - Avoid exposing a drive to temperature extremes or liquids.
 - If a drive must be mailed, place the drive in a bubble pack mailer or other suitable form of protective packaging and label the package "FRAGILE."
-

Grounding guidelines

Electrostatic discharge damage

Electronic components are sensitive to electrostatic discharge (ESD). Circuitry design and structure determine the degree of sensitivity. Networks built into many integrated circuits provide some protection, but in many cases, ESD contains enough power to alter device parameters or melt silicon junctions.

A discharge of static electricity from a finger or other conductor can destroy static-sensitive devices or microcircuitry. Even if the spark is neither felt nor heard, damage may have occurred.

An electronic device exposed to ESD may not be affected at all and can work perfectly throughout a normal cycle. Or, the device may function normally for a while, and then degrade in the internal layers, reducing its life expectancy.

 **CAUTION:** To prevent damage to the computer when you are removing or installing internal components, observe these precautions:

- Keep components in their electrostatic-safe containers until you are ready to install them.
 - Use nonmagnetic tools.
 - Before touching an electronic component, discharge static electricity by using the guidelines described in this section.
 - Avoid touching pins, leads, and circuitry. Handle electronic components as little as possible.
 - If you remove a component, place it in an electrostatic-safe container.
-

The following table shows how humidity affects the electrostatic voltage levels generated by different activities.



CAUTION: A product can be degraded by as little as 700 V.

Typical electrostatic voltage levels			
Event	Relative humidity		
	10%	40%	55%
Walking across carpet	35,000 V	15,000 V	7,500 V
Walking across vinyl floor	12,000 V	5,000 V	3,000 V
Motions of bench worker	6,000 V	800 V	400 V
Removing DIPS from plastic tube	2,000 V	700 V	400 V
Removing DIPS from vinyl tray	11,500 V	4,000 V	2,000 V
Removing DIPS from Styrofoam	14,500 V	5,000 V	3,500 V
Removing bubble pack from PCB	26,500 V	20,000 V	7,000 V
Packing PCBs in foam-lined box	21,000 V	11,000 V	5,000 V

Packaging and transporting guidelines

Follow these grounding guidelines when packaging and transporting equipment:

- To avoid hand contact, transport products in static-safe tubes, bags, or boxes.
- Protect ESD-sensitive parts and assemblies with conductive or approved containers or packaging.
- Keep ESD-sensitive parts in their containers until they arrive at static-free workstations.
- Place items on a grounded surface before them from their containers.
- Always be properly grounded when touching a component or assembly.
- Store reusable ESD-sensitive parts from assemblies in protective packaging or nonconductive foam.
- Use transporters and conveyors made of antistatic belts and roller bushings. Be sure that mechanized equipment used for moving materials is wired to ground, and that proper materials are selected to avoid static charging. When grounding is not possible, use an ionizer to dissipate electric charges.

Workstation guidelines

Follow these workstation grounding guidelines:

- Cover the workstation with approved static-shielding material.
- Use a wrist strap connected to a properly grounded work surface, and use properly grounded tools and equipment.
- Use conductive field service tools, such as cutters, screwdrivers, and vacuums.
- When fixtures must directly contact dissipative surfaces, use fixtures made only of static-safe materials.
- Keep the work area free of nonconductive materials, such as ordinary plastic assembly aids and Styrofoam.
- Handle ESD-sensitive components, parts, and assemblies by the case or PCM laminate. Handle these items only at static-free workstations.
- Avoid contact with pins, leads, or circuitry.
- Turn off power and input signals before inserting or removing connectors or test equipment.

Equipment guidelines

Grounding equipment must include either a wrist strap or a foot strap at a grounded workstation.

- When seated, wear a wrist strap connected to a grounded system. Wrist straps are flexible straps with a minimum of one megohm $\pm 10\%$ resistance in the ground cords. To provide proper ground, wear a strap snugly against the skin at all times. On grounded mats with banana-plug connectors, use alligator clips to connect a wrist strap.
- When standing, use foot straps and a grounded floor mat. Foot straps (heel, toe, or boot straps) can be used at standing workstations and are compatible with most types of shoes or boots. On conductive floors or dissipative floor mats, use foot straps on both feet with a minimum of one megohm resistance between the operator and ground. To be effective, the conductive strips must be worn in contact with the skin.

The following grounding equipment is recommended to prevent electrostatic damage:

- Antistatic tape
- Antistatic smocks, aprons, and sleeve protectors
- Conductive bins and other assembly or soldering aids
- Nonconductive foam
- Conductive tabletop workstations with ground cords of one megohm resistance
- Static-dissipative tables or floor mats with hard ties to the ground
- Field service kits
- Static awareness labels
- Material-handling packages
- Nonconductive plastic bags, tubes, or boxes
- Metal tote boxes
- Electrostatic voltage levels and protective materials

The following table lists the shielding protection provided by antistatic bags and floor mats.

Material	Use	Voltage protection level
Antistatic plastic	Bags	1,500 V
Carbon-loaded plastic	Floor mats	7,500 V
Metallized laminate	Floor mats	5,000 V

Component replacement procedures

This chapter provides removal and replacement procedures.

There are as many as 49 screws, in 6 different sizes, that must be removed, replaced, or loosened when servicing the computer. Make special note of each screw size and location during removal and replacement.

Service tag

When ordering parts or requesting information, provide the computer serial number and model number provided on the service tag.



Item	Component	Description
(1)	Product name	This is the product name affixed to the front of the computer.
(2)	Serial number (s/n)	This is an alphanumeric identifier that is unique to each product.
(3)	Part number/Product number (p/n)	This number provides specific information about the product's hardware components. The part number helps a service technician determine what components and parts are needed.
(4)	Model description	This is the alphanumeric identifier used to locate documents, drivers, and support for the computer.
(5)	Warranty period	This number describes the duration of the warranty period for the computer.

Computer feet

The computer feet are adhesive-backed rubber pads. There are 5 rubber feet that attach to the base enclosure in the locations shown in the following illustration.

Description	Spare part number
Rubber Feet Kit (includes 5 rubber device feet and 8 display bezel screw covers)	580062-001

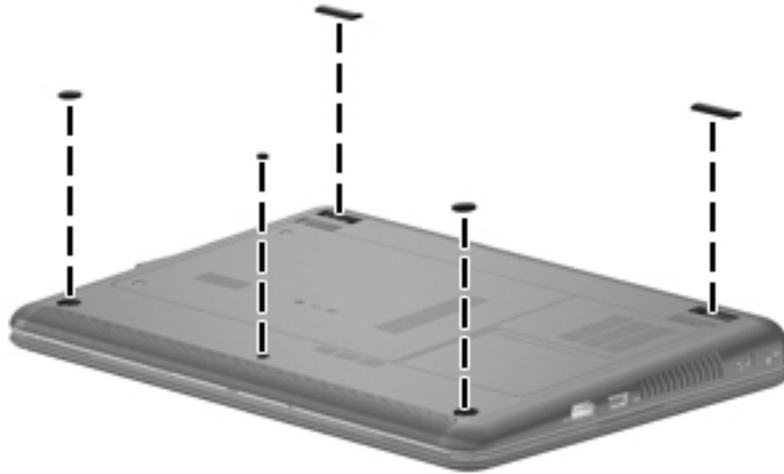

Battery

Description	Spare part number
6-cell, 2.55-Ah (55-Wh) Li-ion battery	580029-001

Before removing the battery, follow these steps:

1. Shut down the computer. If you are unsure whether the computer is off or in Hibernation, turn the computer on, and then shut it down through the operating system.
2. Disconnect all external devices connected to the computer.
3. Disconnect the power from the computer by first unplugging the power cord from the AC outlet, and then unplugging the AC adapter from the computer.

Remove the battery:

1. Turn the computer upside down on a flat surface, with the battery bay toward you.
2. Slide the battery release latches **1** to release the battery.
3. Remove the battery **2**.

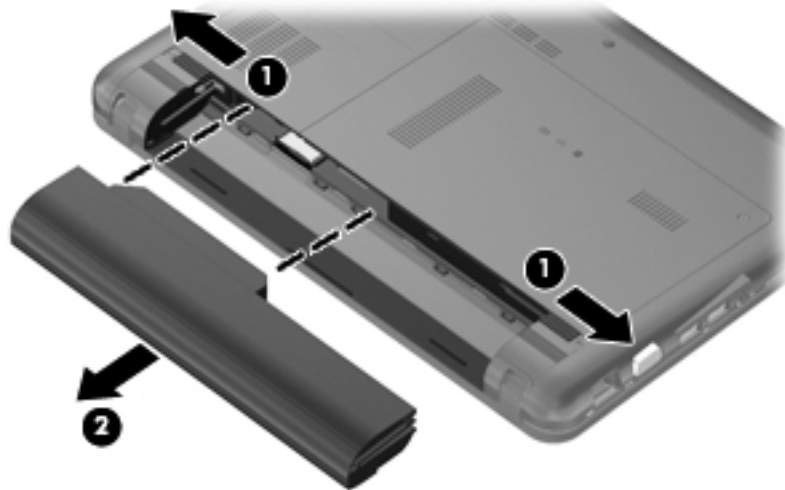

Install the battery by inserting it into the battery bay until you hear a click.

SIM



The SIM is provided by the end user as a security measure for the WWAN module. The SIM should be removed, placed into a static-dissipative container, and then replaced when the computer is reassembled.

Before removing the SIM, follow these steps:

1. Shut down the computer. If you are unsure whether the computer is off or in Hibernation, turn the computer on, and then shut it down through the operating system.
2. Disconnect all external devices connected to the computer.
3. Disconnect the power from the computer by first unplugging the power cord from the AC outlet, and then unplugging the AC adapter from the computer.
4. Remove the battery (see [“Battery” on page 4-7](#)).

Remove the SIM:

1. Press in on the SIM **1** to release it from the SIM slot.
2. Remove the SIM **2** from the computer.

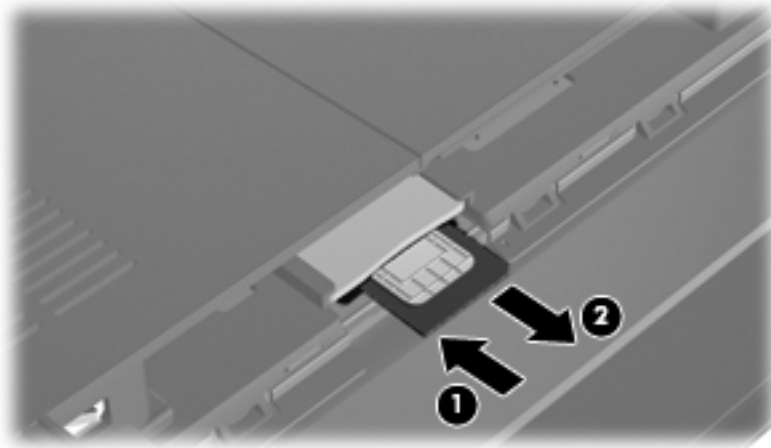

Install the SIM by inserting it into the SIM slot until you hear a click.

WLAN module

Description	Spare part number
802.11b/g/n WLAN module:	
<ul style="list-style-type: none"> ■ Broadcom 4322AGN 802.11b/g/n WLAN module for use in Canada, the Cayman Islands, Guam, Puerto Rico, the United States, and the U.S. Virgin Islands 	518436-001
<ul style="list-style-type: none"> ■ Broadcom 4322AGN 802.11b/g/n WLAN module for use in Afghanistan, Albania, Algeria, Andorra, Angola, Antigua and Barbuda, Argentina, Armenia, Aruba, Australia, Austria, Azerbaijan, the Bahamas, Bahrain, Bangladesh, Barbados, Belarus, Belgium, Belize, Benin, Bermuda, Bhutan, Bolivia, Bosnia and Herzegovina, Botswana, Brazil, the British Virgin Islands, Brunei, Bulgaria, Burkina Faso, Burundi, Cambodia, Cameroon, Cape Verde, the Central African Republic, Chad, Colombia, Comoros, the Congo, Costa Rica, Croatia, Cyprus, the Czech Republic, Denmark, Djibouti, Dominica, the Dominican Republic, East Timor, Ecuador, Egypt, El Salvador, Equatorial Guinea, Eritrea, Estonia, Ethiopia, Fiji, Finland, France, French Guiana, Gabon, Gambia, Georgia, Germany, Ghana, Gibraltar, Greece, Grenada, Guadeloupe, Guatemala, Guinea, Guinea-Bissau, Guyana, Haiti, Honduras, Hong Kong, Hungary, Iceland, India, Indonesia, Ireland, Israel, Italy, the Ivory Coast, Jamaica, Japan, Jordan, Kazakhstan, Kenya, Kiribati, Kuwait, Kyrgyzstan, Laos, Latvia, Lebanon, Lesotho, Liberia, Liechtenstein, Lithuania, Luxembourg, Macedonia, Madagascar, Malawi, Malaysia, the Maldives, Mali, Malta, the Marshall Islands, Martinique, Mauritania, Mauritius, Mexico, Micronesia, Monaco, Mongolia, Montenegro, Morocco, Mozambique, Namibia, Nauru, Nepal, the Nether Antilles, the Netherlands, New Zealand, Nicaragua, Niger, Nigeria, Norway, Oman, Pakistan, Palau, Panama, Papua New Guinea, Paraguay, the People's Republic of China, Peru, the Philippines, Poland, Portugal, Qatar, the Republic of Moldova, Romania, Russia, Rwanda, Samoa, San Marino, Sao Tome and Principe, Saudi Arabia, Senegal, Serbia, the Seychelles, Sierra Leone, Singapore, Slovakia, Slovenia, the Solomon Islands, Somalia, South Africa, South Korea, Spain, Sri Lanka, St. Kitts and Nevis, St. Lucia, St. Vincent and the Grenadines, Suriname, Swaziland, Sweden, Switzerland, Syria, Taiwan, Tajikistan, Tanzania, Thailand, Togo, Tonga, Trinidad and Tobago, Tunisia, Turkey, Turkmenistan, Tuvalu, Uganda, Ukraine, the United Arab Emirates, the United Kingdom, Uruguay, Uzbekistan, Vanuatu, Venezuela, Vietnam, Yemen, Zaire, Zambia, and Zimbabwe 	518436-002
Intel Wi-Fi Link 5100 802.11b/g WLAN module for use with the HP Mini and Compaq Mini only in Pakistan, Russia, and the Ukraine	482957-001

(Continued)

Description	Spare part number
802.11b/g WLAN module:	
WLAN/Bluetooth combo card	575920-001
Broadcom 4312G 802.11b/g WLAN module for use in Canada, the Cayman Islands, Guam, Puerto Rico, the United States, and the U.S. Virgin Islands	504593-003
Broadcom 4312G 802.11b/g WLAN module for use in Afghanistan, Albania, Algeria, Andorra, Angola, Antigua and Barbuda, Argentina, Armenia, Aruba, Australia, Austria, Azerbaijan, the Bahamas, Bahrain, Bangladesh, Barbados, Belarus, Belgium, Belize, Benin, Bermuda, Bhutan, Bolivia, Bosnia and Herzegovina, Botswana, Brazil, the British Virgin Islands, Brunei, Bulgaria, Burkina Faso, Burundi, Cambodia, Cameroon, Cape Verde, the Central African Republic, Chad, Colombia, Comoros, the Congo, Costa Rica, Croatia, Cyprus, the Czech Republic, Denmark, Djibouti, Dominica, the Dominican Republic, East Timor, Ecuador, Egypt, El Salvador, Equatorial Guinea, Eritrea, Estonia, Ethiopia, Fiji, Finland, France, French Guiana, Gabon, Gambia, Georgia, Germany, Ghana, Gibraltar, Greece, Grenada, Guadeloupe, Guatemala, Guinea, Guinea-Bissau, Guyana, Haiti, Honduras, Hong Kong, Hungary, Iceland, India, Indonesia, Ireland, Israel, Italy, the Ivory Coast, Jamaica, Japan, Jordan, Kazakhstan, Kenya, Kiribati, Kuwait, Kyrgyzstan, Laos, Latvia, Lebanon, Lesotho, Liberia, Liechtenstein, Lithuania, Luxembourg, Macedonia, Madagascar, Malawi, Malaysia, the Maldives, Mali, Malta, the Marshall Islands, Martinique, Mauritania, Mauritius, Mexico, Micronesia, Monaco, Mongolia, Montenegro, Morocco, Mozambique, Namibia, Nauru, Nepal, the Nether Antilles, the Netherlands, New Zealand, Nicaragua, Niger, Nigeria, Norway, Oman, Pakistan, Palau, Panama, Papua New Guinea, Paraguay, the People's Republic of China, Peru, the Philippines, Poland, Portugal, Qatar, the Republic of Moldova, Romania, Russia, Rwanda, Samoa, San Marino, Sao Tome and Principe, Saudi Arabia, Senegal, Serbia, the Seychelles, Sierra Leone, Singapore, Slovakia, Slovenia, the Solomon Islands, Somalia, South Africa, South Korea, Spain, Sri Lanka, St. Kitts and Nevis, St. Lucia, St. Vincent and the Grenadines, Suriname, Swaziland, Sweden, Switzerland, Syria, Taiwan, Tajikistan, Tanzania, Thailand, Togo, Tonga, Trinidad and Tobago, Tunisia, Turkey, Turkmenistan, Tuvalu, Uganda, Ukraine, the United Arab Emirates, the United Kingdom, Uruguay, Uzbekistan, Vanuatu, Venezuela, Vietnam, Yemen, Zaire, Zambia, and Zimbabwe	504593-004
Broadcom 4322AGN 802.11a/b/g/n WLAN module for use in Afghanistan, Albania, Algeria, Andorra, Angola, Antigua and Barbuda, Argentina, Armenia, Aruba, Australia, Austria, Azerbaijan, the Bahamas, Bahrain, Bangladesh, Barbados, Belarus, Belgium, Belize, Benin, Bermuda, Bhutan, Bolivia, Bosnia and Herzegovina, Botswana, Brazil, the British Virgin Islands, Brunei, Bulgaria, Burkina Faso, Burundi, Cambodia, Cameroon, Cape Verde, the Central African Republic, Chad, Colombia, Comoros, the Congo, Costa Rica, Croatia, Cyprus, the Czech Republic, Denmark, Djibouti, Dominica, the Dominican Republic, East Timor, Ecuador, Egypt, El Salvador, Equatorial Guinea, Eritrea, Estonia, Ethiopia, Fiji, Finland, France, French Guiana, Gabon, Gambia, Georgia, Germany, Ghana, Gibraltar, Greece, Grenada, Guadeloupe, Guatemala, Guinea, Guinea-Bissau, Guyana, Haiti, Honduras, Hong Kong, Hungary, Iceland, India, Indonesia, Ireland, Israel, Italy, the Ivory Coast, Jamaica, Japan, Jordan, Kazakhstan, Kenya, Kiribati, Kuwait, Kyrgyzstan, Laos, Latvia, Lebanon, Lesotho, Liberia, Liechtenstein, Lithuania, Luxembourg, Macedonia, Madagascar, Malawi, Malaysia, the Maldives, Mali, Malta, the Marshall Islands, Martinique, Mauritania, Mauritius, Mexico, Micronesia, Monaco, Mongolia, Montenegro, Morocco, Mozambique, Namibia, Nauru, Nepal, the Nether Antilles, the Netherlands, New Zealand, Nicaragua, Niger, Nigeria, Norway, Oman, Pakistan, Palau, Panama, Papua New Guinea, Paraguay, the People's Republic of China, Peru, the Philippines, Poland, Portugal, Qatar, the Republic of Moldova, Romania, Russia, Rwanda, Samoa, San Marino, Sao Tome and Principe, Saudi Arabia, Senegal, Serbia, the Seychelles, Sierra Leone, Singapore, Slovakia, Slovenia, the Solomon Islands, Somalia, South Africa, South Korea, Spain, Sri Lanka, St. Kitts and Nevis, St. Lucia, St. Vincent and the Grenadines, Suriname, Swaziland, Sweden, Switzerland, Syria, Taiwan, Tajikistan, Tanzania, Thailand, Togo, Tonga, Trinidad and Tobago, Tunisia, Turkey, Turkmenistan, Tuvalu, Uganda, Ukraine, the United Arab Emirates, the United Kingdom, Uruguay, Uzbekistan, Vanuatu, Venezuela, Vietnam, Yemen, Zaire, Zambia, and Zimbabwe	518434-002

Before removing the WLAN module, follow these steps:

1. Shut down the computer. If you are unsure whether the computer is off or in Hibernation, turn the computer on, and then shut it down through the operating system.
2. Disconnect all external devices connected to the computer.
3. Disconnect the power from the computer by first unplugging the power cord from the AC outlet, and then unplugging the AC adapter from the computer.
4. Remove the battery (see “Battery” on page 4-7).

Remove the WLAN module:



CAUTION: To prevent an unresponsive system, replace the wireless module only with a wireless module authorized for use in the computer by the governmental agency that regulates wireless devices in your country or region. If you replace the module and then receive a warning message, remove the module to restore computer functionality, and then contact technical support through Help and Support.

1. Position the computer with the front toward you.
2. Loosen the 2 Phillips PM2.0×6.0 captive screws ❶ that secure the accessory compartment cover to the computer.
3. Lift the left side of the cover ❷ to detach it from the computer, and remove the accessory compartment cover.

 The accessory compartment cover is available using spare part number 580056-001.



4. Disconnect the WLAN antenna cables **1** from the terminals on the WLAN module.

 The black WLAN antenna cable is connected to the WLAN module “Main” terminal. The white WLAN antenna cable is connected to the WLAN module “Aux” terminal.

5. Remove the Phillips PM2.0×4.0 screw **2** that secures the WLAN module to the system board. (The WLAN module tilts up.)

6. Remove the WLAN module **3** by pulling it away from the slot at an angle.

 WLAN modules are designed with a notch **4** to prevent incorrect insertion of the WLAN module into the WLAN module slot.

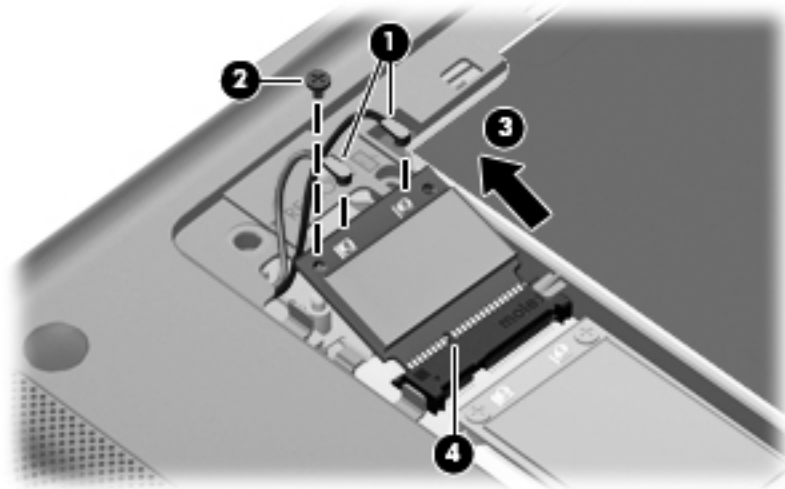

Reverse this procedure to install the WLAN module.

WWAN module

Description	Spare part number
HSPA EV-DO WWAN module for use with the HP Mini and Compaq Mini in all countries and regions except the People's Republic of China	483377-002
HSPA EV-DO WWAN module for use with the HP Mini and Compaq Mini in the People's Republic of China	483377-003
UNDP HSPA EV-DO WWAN mini module	531993-001

Before removing the WWAN module, follow these steps:

1. Shut down the computer. If you are unsure whether the computer is off or in Hibernation, turn the computer on, and then shut it down through the operating system.
2. Disconnect all external devices connected to the computer.
3. Disconnect the power from the computer by first unplugging the power cord from the AC outlet, and then unplugging the AC adapter from the computer.
4. Remove the battery (see “[Battery](#)” on page 4-7).
5. Remove the accessory compartment cover (see “[WLAN module](#)” on page 4-9).

Remove the WWAN module:

CAUTION: To prevent an unresponsive system, replace the wireless module only with a wireless module authorized for use in the computer by the governmental agency that regulates wireless devices in your country or region. If you replace the module and then receive a warning message, remove the module to restore computer functionality, and then contact technical support through Help and Support.

1. Position the computer with the front toward you.
2. Disconnect the WWAN antenna cables ❶ from the terminals on the WWAN module.
 - ✎ The red WWAN antenna cable is connected to the WWAN module “Main” terminal. The blue WWAN antenna cable is connected to the WWAN module “Aux” terminal.
3. Remove the 2 Phillips PM2.0×4.0 screws ❷ that secure the WWAN module to the system board. (The WWAN module tilts up.)
4. Remove the WWAN module ❸ by pulling it away from the slot at an angle.
 - ✎ WWAN modules are designed with a notch ❹ to prevent incorrect insertion of the WWAN module into the WWAN module slot.

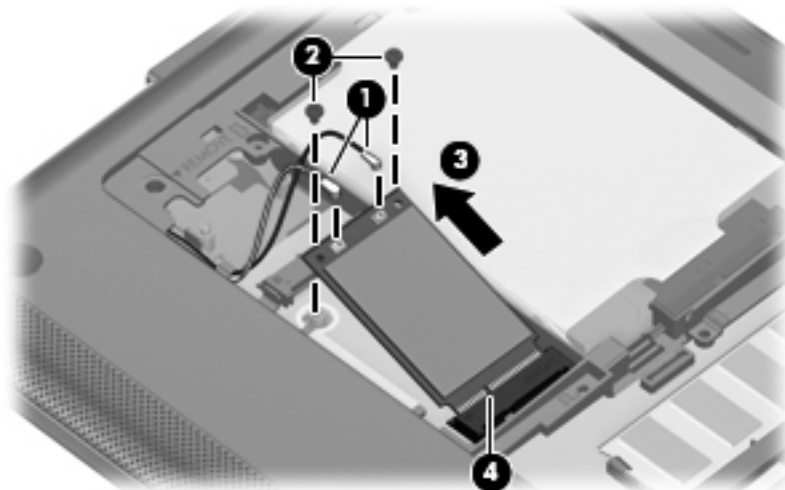

Reverse this procedure to install the WWAN module.

RTC battery

Description	Spare part number
RTC battery	580055-001

Before removing the RTC battery, follow these steps:

1. Shut down the computer. If you are unsure whether the computer is off or in Hibernation, turn the computer on, and then shut it down through the operating system.
2. Disconnect all external devices connected to the computer.
3. Disconnect the power from the computer by first unplugging the power cord from the AC outlet, and then unplugging the AC adapter from the computer.
4. Remove the battery (see [“Battery” on page 4-7](#)).
5. Remove the accessory compartment cover (see [“WLAN module” on page 4-9](#)).

Remove the RTC battery:

1. Position the computer with the front toward you.
2. Disconnect the RTC battery cable ❶ from the system board.
3. Slide the RTC battery ❷ directly back to remove it.

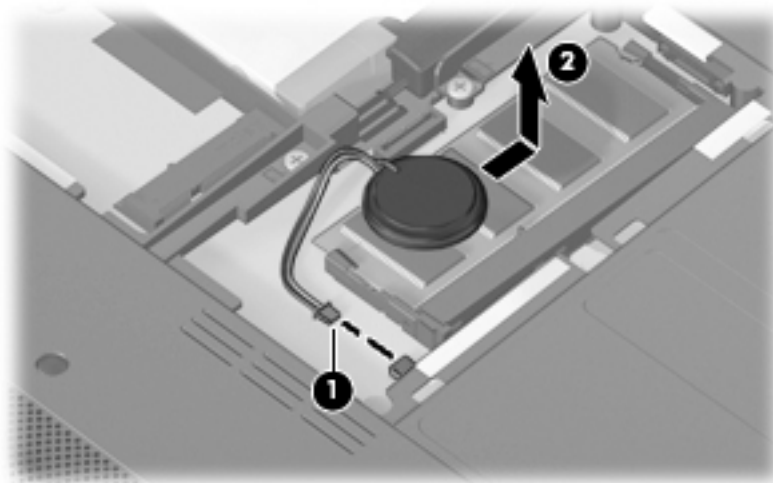

Reverse this procedure to install the RTC battery.

Expansion memory module

Description	Spare part number
4096-MB expansion memory module (1333-MHz, DDR3), for use with the HP Pavilion	518754-002
4096-MB expansion memory module (1333-MHz, DDR3), for use with the HP Pavilion in systems that include a WWAN module	581754-001
2048-MB (1333-MHz, DDR2)	580017-001
2048-MB (1333-MHz, DDR2), for use with the HP Mini and Compaq Mini in systems that include a WWAN module	580017-002
2048-MB (1333-MHz, DDR3), for use with the HP Pavilion in systems that include a WWAN module	591374-001
1024-MB (1333-MHz, DDR2)	580016-001
1024-MB (1333-MHz, DDR2), for use with the HP Mini and Compaq Mini in systems that include a WWAN module	580016-002
1024-MB (1333-MHz, DDR2), for use with the HP Pavilion in systems that include a WWAN module	591373-001

Before removing the expansion memory module, follow these steps:

1. Shut down the computer. If you are unsure whether the computer is off or in Hibernation, turn the computer on, and then shut it down through the operating system.
2. Disconnect all external devices connected to the computer.
3. Disconnect the power from the computer by first unplugging the power cord from the AC outlet, and then unplugging the AC adapter from the computer.
4. Remove the battery (see [“Battery” on page 4-7](#)).
5. Remove the accessory compartment cover (see [“WLAN module” on page 4-9](#)).

Remove the expansion memory module:



1024-MB primary memory is included on the system board. Expansion memory is customer-accessible/upgradable and is located in the accessory compartment.

1. Pull away the retention clips ❶ on each side of the memory module to release the memory module. (The memory module tilts up.)



CAUTION: To prevent damage to the memory module, hold it by the edges only. Do not touch the components on the memory module.

2. Grasp the edge of the memory module ❷, and then pull it out of the memory module slot.



Memory modules are designed with a notch ❸ to prevent incorrect insertion into the memory module slot.

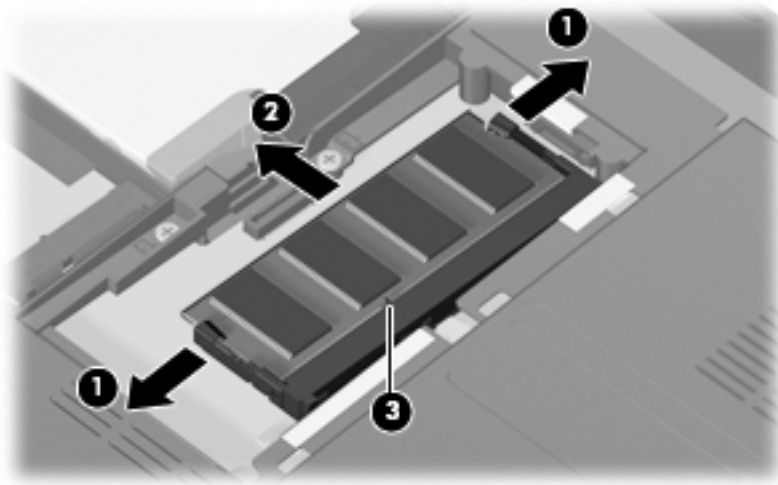

Reverse this procedure to install an expansion memory module.

Hard drive



The hard drive spare part kit includes a hard drive connector and hard drive bracket.

Description	Spare part number
500-GB, 5400-rpm for use with HP Pavilion	584512-001
500-GB, 5400-rpm, for use with the HP Pavilion in systems that include a WWAN module	591372-001
320-GB, 5400-rpm	580020-001
320-GB, 5400-rpm, for use HP Mini and Compaq Mini in systems that include a WWAN module	580020-002
320-GB, 5400-rpm, for use with the HP Pavilion in systems that include a WWAN module	591371-001
250-GB, 5400-rpm	580019-001
250-GB, 5400-rpm, for use with the HP Mini and Compaq Mini in systems that include a WWAN module	580019-002
250-GB, 5400-rpm, for use with the HP Pavilion in systems that include a WWAN module	591370-001
160-GB, 7200-rpm	591250-001
160-GB, 5400-rpm	580018-001
160-GB, 5400-rpm, for use with the HP Mini and Compaq Mini in systems that include a WWAN module	580018-002
160-GB, 5400-rpm, for use with the HP Pavilion in systems that include a WWAN module	591369-001
80-GB solid state drive (SSD)	584513-001

Before removing the hard drive, follow these steps:

1. Shut down the computer. If you are unsure whether the computer is off or in Hibernation, turn the computer on, and then shut it down through the operating system.
2. Disconnect all external devices connected to the computer.
3. Disconnect the power from the computer by first unplugging the power cord from the AC outlet, and then unplugging the AC adapter from the computer.
4. Remove the battery (see [“Battery” on page 4-7](#)).
5. Remove the accessory compartment cover (see [“WLAN module” on page 4-9](#)).

Remove the hard drive:

1. Position the computer with the front toward you.
2. Disconnect the hard drive connector ❶.
3. Grasp the Mylar tab ❷ in the hard drive bay, and then lift it up at an angle.

4. Remove the hard drive ③ from the hard drive bay.

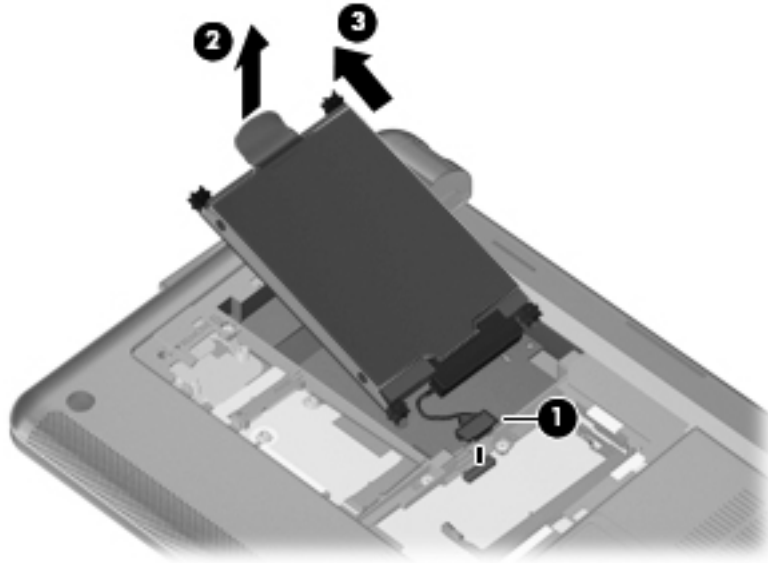

5. If it is necessary to replace the hard drive bracket or connector, follow these steps:
 - a. Disconnect the hard drive connector ❶ from the hard drive.
 - b. Remove the 4 isolators ❷ from the 4 corners of the hard drive bracket.
 - c. Remove the 4 Phillips PM3.0×4.0 screws ❸ that secure the hard drive bracket to the hard drive.
 - d. Lift the bracket ❹ straight up to remove it from the hard drive.

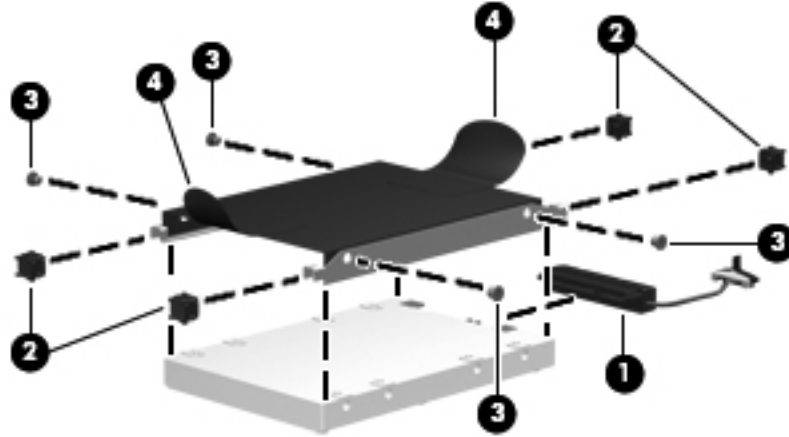

Reverse this procedure to reassemble and install the hard drive.

Keyboard



The keyboard spare part kit includes a keyboard cable.

Description	Spare part number
For use in Belgium	580030-A41
For use in the Czech Republic	580030-221
For use in Demark	580030-DH1
For use in France	580030-051
For use with the HP Mini and Compaq Mini in French Canada	580030-121
For use in Germany	580030-041
For use in Greece	580030-DJ1
For use in Hungary	580030-211
For use in Israel	580030-BB1
For use in Italy	580030-061
For use in Japan	580030-291
For use in the Netherlands	580030-B31
For use in Portugal	580030-131
For use in Russia	580030-251
For use in Saudi Arabia	580030-171
For use in South Korea	280030-AD1
For use in Spain	580030-071
For use in Switzerland	580030-BG1
For use in Taiwan	580030-AB1
For use in Thailand	580030-281
For use in Turkey	580030-141
For use in the United Kingdom	580030-031
For use in the United States	580030-001

Before removing the keyboard, follow these steps:

1. Shut down the computer. If you are unsure whether the computer is off or in Hibernation, turn the computer on, and then shut it down through the operating system.
2. Disconnect all external devices connected to the computer.
3. Disconnect the power from the computer by first unplugging the power cord from the AC outlet, and then unplugging the AC adapter from the computer.
4. Remove the battery (see [“Battery” on page 4-7](#)).
5. Remove the accessory compartment cover (see [“WLAN module” on page 4-9](#)).
6. Remove the hard drive (see [“Hard drive” on page 4-18](#)).

Remove the keyboard:

1. Position the computer with the front toward you.
2. Remove the 4 Phillips PM2.0×7.0 screws that secure the keyboard to the computer.

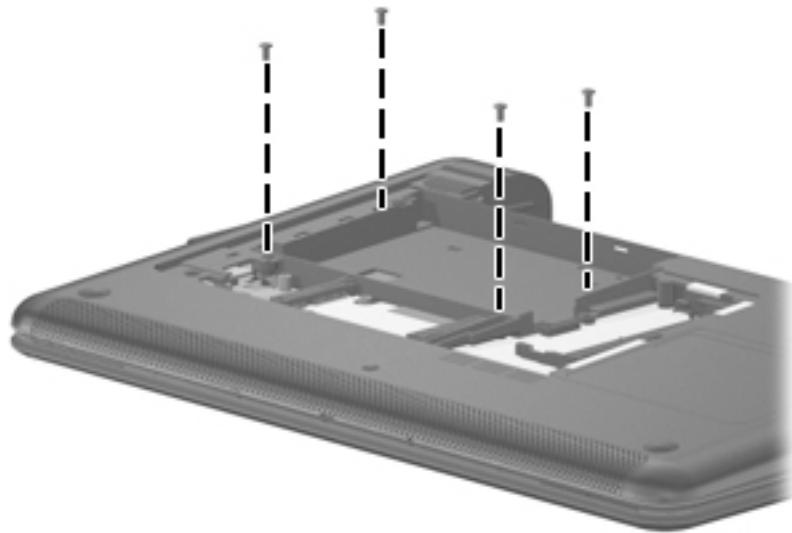

3. Turn the computer display-side up, with the front toward you.
4. Open the computer as far as possible.
5. Lift the rear edge ❶ and then the left edge ❷ of the keyboard until it rests at an angle.
6. Slide the keyboard ❸ back until it rests on the display.

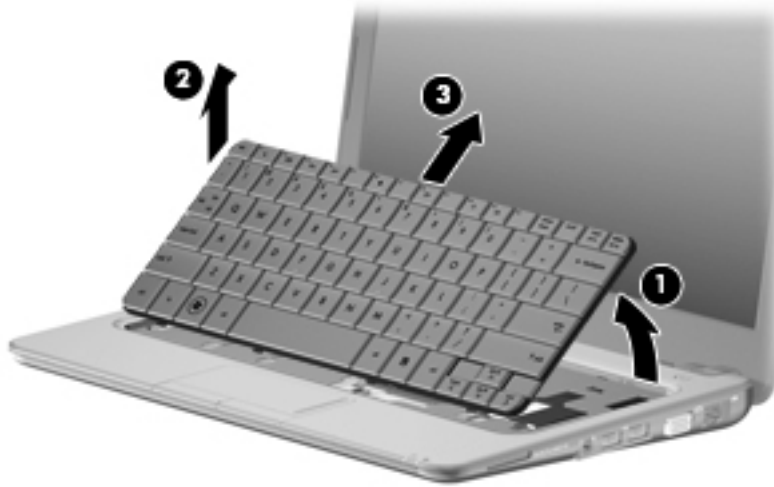

7. Release the zero insertion force (ZIF) connector ❶ to which the keyboard cable is attached, and then disconnect the keyboard cable ❷ from the system board.

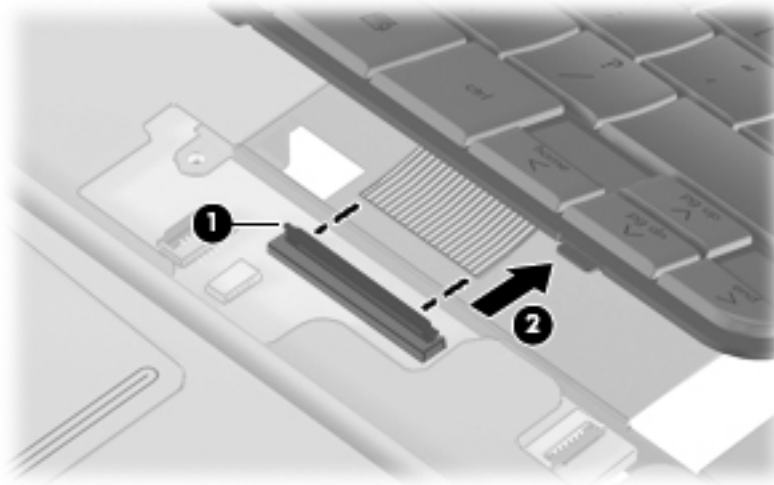

8. Remove the keyboard.
- Reverse this procedure to install the keyboard.

Top cover

Description	Spare part number
Top cover (includes TouchPad button board and cable, and TouchPad board and cable)	580057-001

Before removing the top cover, follow these steps:

1. Shut down the computer. If you are unsure whether the computer is off or in Hibernation, turn the computer on, and then shut it down through the operating system.
2. Disconnect all external devices connected to the computer.
3. Disconnect the power from the computer by first unplugging the power cord from the AC outlet, and then unplugging the AC adapter from the computer.
4. Remove the battery (see [“Battery” on page 4-7](#)).
5. Remove the accessory compartment cover (see [“WLAN module” on page 4-9](#)).
6. Remove the hard drive (see [“Hard drive” on page 4-18](#)).
7. Remove the keyboard (see [“Keyboard” on page 4-21](#)).

Remove the top cover:

1. Turn the computer upside down, with the front toward you.
2. Remove the 2 Phillips PM2.0×12.0 screws **1** and the 3 Phillips PM2.0×7.0 screws **2**, located under the rubber device feet, that secure the top cover to the base enclosure.

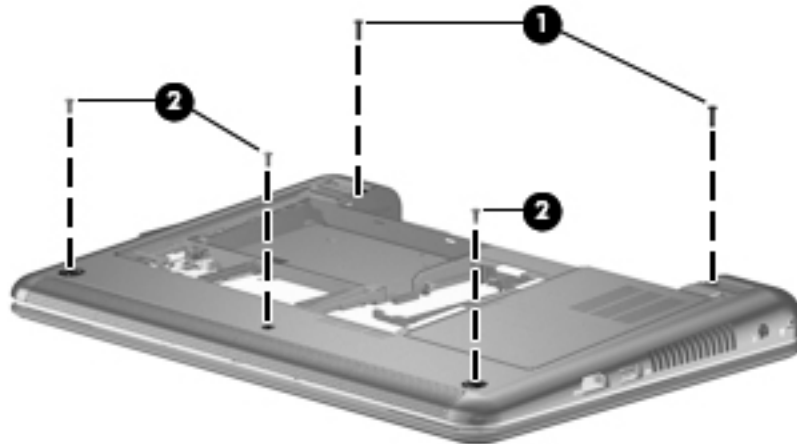

3. Turn the computer right-side up, with the front toward you and the display open as far as possible.
4. Release and disconnect the following low insertion force (LIF) connector cables from the system board:
 - a. Power button board cable ❶
 - b. TouchPad cable ❷
 - c. TouchPad button board cable ❸
 - d. WLAN button cable ❹

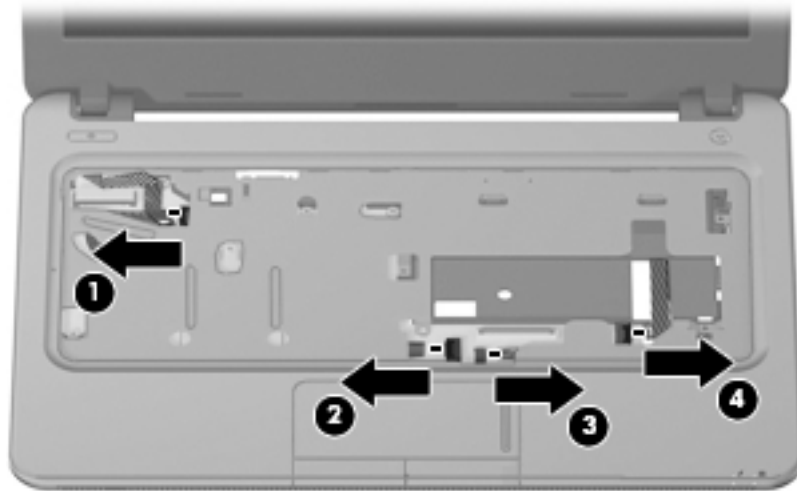

5. Remove the 4 Phillips PM2.0×7.0 screws that secure the top cover to the base enclosure.

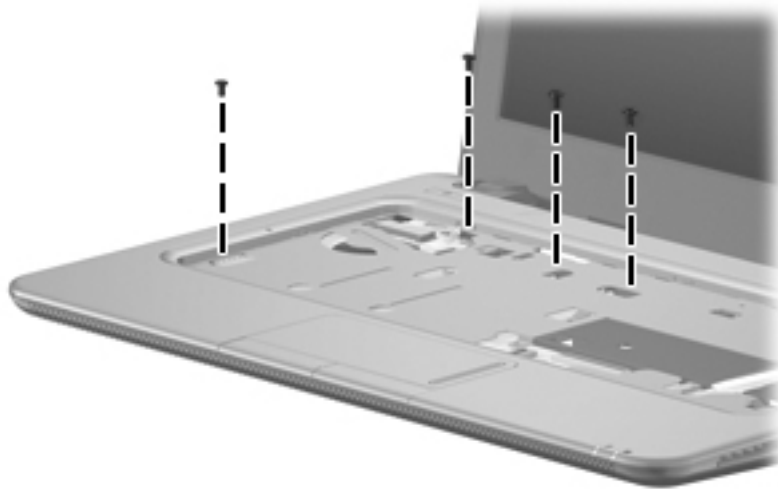

6. Lift the rear edge ❶ of the top cover until it detaches from the base enclosure.
7. Remove the top cover ❷ by lifting it straight up.



Reverse this procedure to install the top cover.

Wireless button board

Description	Spare part number
Wireless button board (includes cable)	580060-001

Before removing the wireless button board, follow these steps:

1. Shut down the computer. If you are unsure whether the computer is off or in Hibernation, turn the computer on, and then shut it down through the operating system.
2. Disconnect all external devices connected to the computer.
3. Disconnect the power from the computer by first unplugging the power cord from the AC outlet, and then unplugging the AC adapter from the computer.
4. Remove the battery (see [“Battery” on page 4-7](#)).
5. Remove the accessory compartment cover (see [“WLAN module” on page 4-9](#)).
6. Remove the hard drive (see [“Hard drive” on page 4-18](#)).
7. Remove the keyboard (see [“Keyboard” on page 4-21](#)).
8. Remove the top cover (see [“Top cover” on page 4-24](#)).

Remove the wireless button board:

1. Turn the top cover upside down, with the front toward you.
2. Remove the Phillips PM2.0×4.0 screw ❶ that secures the wireless button board to the top cover.
3. Remove the wireless button board ❷.

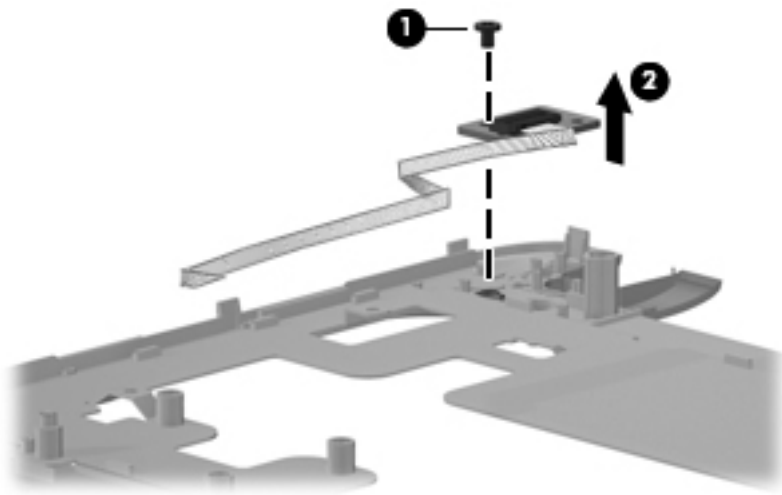

Reverse this procedure to install the wireless button board.

Power button board

Description	Spare part number
Power button board (includes cable)	580058-001

Before removing the power button board, follow these steps:

1. Shut down the computer. If you are unsure whether the computer is off or in Hibernation, turn the computer on, and then shut it down through the operating system.
2. Disconnect all external devices connected to the computer.
3. Disconnect the power from the computer by first unplugging the power cord from the AC outlet, and then unplugging the AC adapter from the computer.
4. Remove the battery (see [“Battery” on page 4-7](#)).
5. Remove the accessory compartment cover (see [“WLAN module” on page 4-9](#)).
6. Remove the hard drive (see [“Hard drive” on page 4-18](#)).
7. Remove the keyboard (see [“Keyboard” on page 4-21](#)).
8. Remove the top cover (see [“Top cover” on page 4-24](#)).

Remove the power button board:

1. Turn the top cover upside down, with the front toward you.
2. Remove the Phillips PM2.0×4.0 screw ❶ that secures the power button board to the top cover.
3. Remove the power button board ❷.

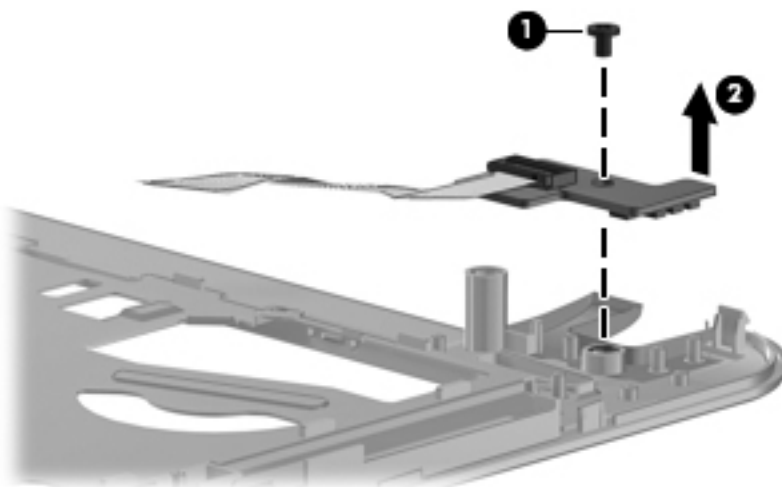

Reverse this procedure to install the power button board.

Speakers

Description	Spare part number
Speakers (include cables)	580064-001

Before removing the speakers, follow these steps:

1. Shut down the computer. If you are unsure whether the computer is off or in Hibernation, turn the computer on, and then shut it down through the operating system.
2. Disconnect all external devices connected to the computer.
3. Disconnect the power from the computer by first unplugging the power cord from the AC outlet, and then unplugging the AC adapter from the computer.
4. Remove the battery (see [“Battery” on page 4-7](#)).
5. Remove the accessory compartment cover (see [“WLAN module” on page 4-9](#)).
6. Remove the hard drive (see [“Hard drive” on page 4-18](#)).
7. Remove the keyboard (see [“Keyboard” on page 4-21](#)).
8. Remove the top cover (see [“Top cover” on page 4-24](#)).

Remove the speakers:

1. Turn the computer right-side up, with the front toward you and the display open as far as possible.
2. Disconnect the speaker cable ❶ from the system board.
3. Remove the 2 Phillips PM2.0×7.0 screws ❷ that secure the speaker assembly to the base enclosure.
4. Remove the speaker assembly ❸.

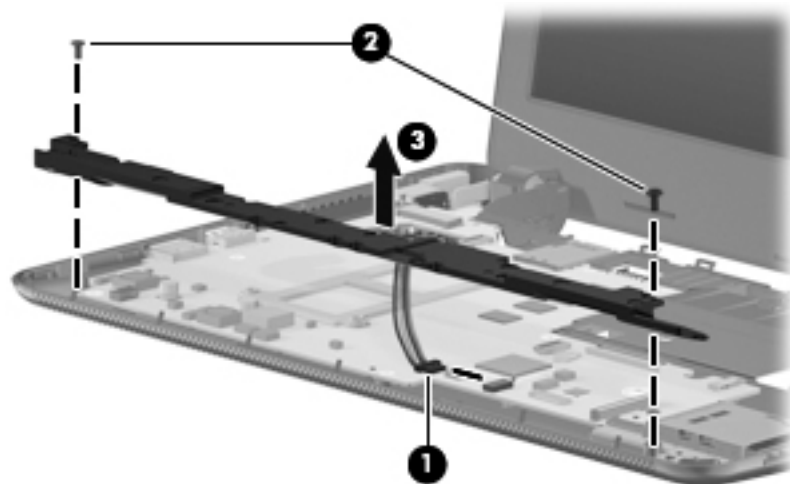

Reverse this procedure to install the speakers.

Digital media assembly

Description	Spare part number
Digital media assembly (includes cable)	580065-001

Before removing the digital media assembly, follow these steps:

1. Shut down the computer. If you are unsure whether the computer is off or in Hibernation, turn the computer on, and then shut it down through the operating system.
2. Disconnect all external devices connected to the computer.
3. Disconnect the power from the computer by first unplugging the power cord from the AC outlet, and then unplugging the AC adapter from the computer.
4. Remove the battery (see [“Battery” on page 4-7](#)).
5. Remove the accessory compartment cover (see [“WLAN module” on page 4-9](#)).
6. Remove the hard drive (see [“Hard drive” on page 4-18](#)).
7. Remove the keyboard (see [“Keyboard” on page 4-21](#)).
8. Remove the top cover (see [“Top cover” on page 4-24](#)).

Remove the digital media assembly:

1. Turn the computer right-side up, with the front toward you and the display open as far as possible.
2. Disconnect the LIF digital media assembly cable ❶.
3. Remove the Phillips PM2.0×4.0 screw ❷ that secures the digital media assembly to the base enclosure.
4. Remove the digital media assembly ❸.

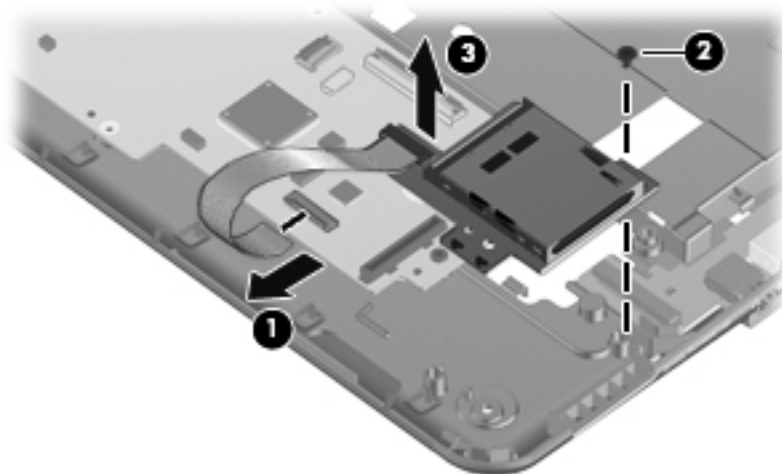

Reverse this procedure to install the digital media assembly.

Display assembly

Description	Spare part number
11.6-in (1366 x 768) HD, BrightView, LED display assembly (includes webcam, microphone, 2 WLAN antenna transceivers and cables, nameplate, and logo):	
Display assembly with 2 WWAN antennas for use with the HP Mini	580006-001
Display assembly for use with the HP Mini	580007-001
Display assembly with 2 WWAN antennas for use with the Compaq Mini	580011-001
Display assembly with 2 WWAN antenna for use with the white-colored HP Pavilion	588690-001
Display assembly with 2 WWAN antenna for use with the black-colored HP Pavilion	588689-001
Display bezel (includes hinge covers):	
For use only with the HP Mini	580010-001
For use only with the Compaq Mini	580015-001
For use only with the HP Pavilion	587312-001
Display panel	580001-001
Display panel/webcam/microphone cable	580003-001
Webcam module	580004-001
Wireless antenna cables	580005-001
Display enclosure (includes hinge and hinge brackets):	
For use with the HP Mini and HP Pavilion	580009-001
For use with the HP Mini and HP Pavilion that includes WWAN	580008-001
For use with the Compaq Mini	580013-001

Before removing the display assembly, follow these steps:

1. Shut down the computer. If you are unsure whether the computer is off or in Hibernation, turn the computer on, and then shut it down through the operating system.
2. Disconnect all external devices connected to the computer.
3. Disconnect the power from the computer by first unplugging the power cord from the AC outlet, and then unplugging the AC adapter from the computer.
4. Remove the battery (see [“Battery” on page 4-7](#)).
5. Remove the accessory compartment cover (see [“WLAN module” on page 4-9](#)).
6. Remove the hard drive (see [“Hard drive” on page 4-18](#)).
7. Disconnect the wireless antenna cables from the WLAN module (see [“WLAN module” on page 4-9](#)) and WWAN module (see [“WWAN module” on page 4-13](#)).
8. Remove the keyboard (see [“Keyboard” on page 4-21](#)).
9. Remove the top cover (see [“Top cover” on page 4-24](#)).

Remove the display assembly:

1. Turn the computer display-side up, with the front toward you.
2. Open the computer as far as possible.
3. Disconnect the display panel/webcam/microphone cable **1** from the system board.
4. Remove the wireless antenna cables from the clips **2** and routing channel built into the base enclosure.

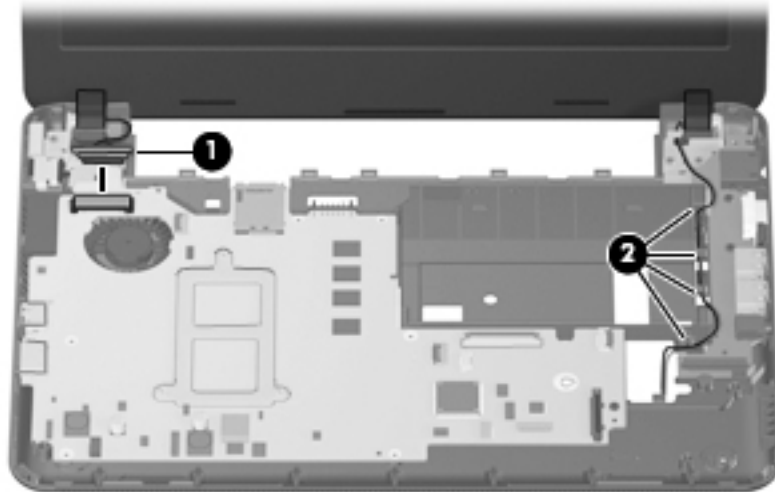

CAUTION: Support the display assembly when removing the following screws. Failure to support the display assembly can result in damage to the display assembly and other computer components.

5. Remove the 4 Phillips PM2.0×7.0 screws ❶ that secure the display assembly to the base enclosure.
6. Lift the display assembly ❷ straight up and remove it.

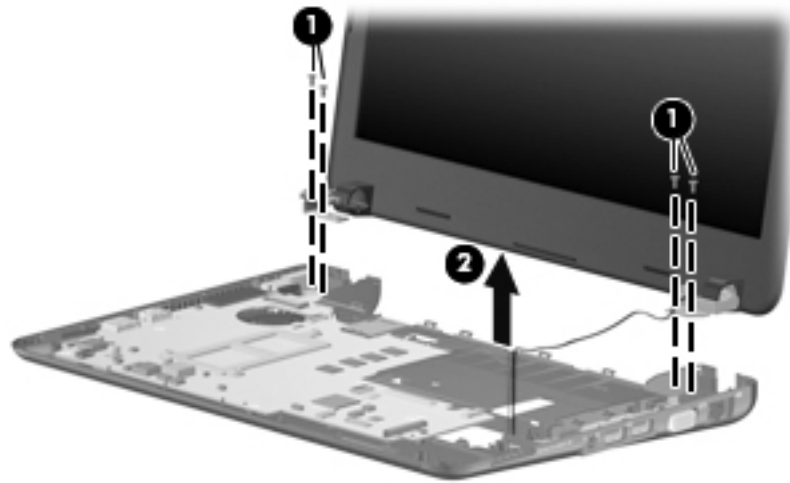

7. If it is necessary to replace the display bezel or any of the display assembly internal components:
 - a. Remove the hinge covers ❶.
 - b. Flex the inside edges of the top edge ❷, the left and right sides ❸, and the bottom edge ❹ of the display bezel until the bezel disengages from the display enclosure.
 - c. Remove the display bezel ❺.

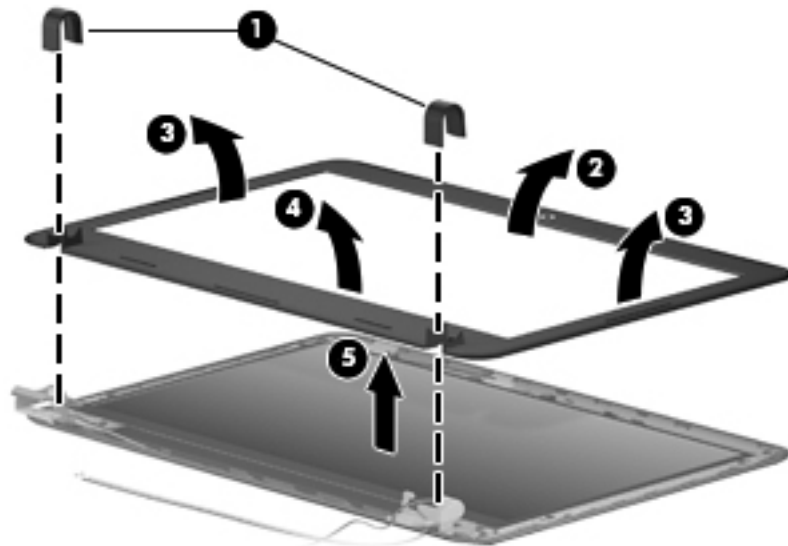

8. If it is necessary to replace the webcam module:

- a. Disconnect the display panel/webcam/microphone cable ❶ from the webcam module.
- b. Remove the webcam module ❷.

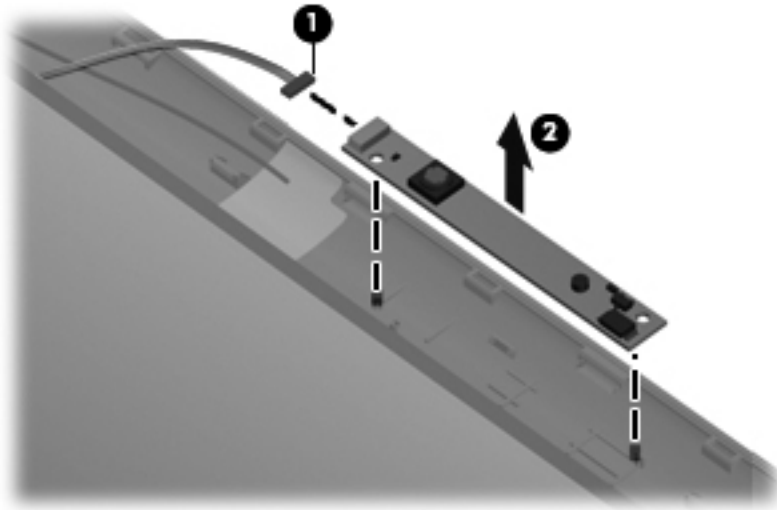

9. If it is necessary to replace the display panel:

- a. Remove the 6 Phillips PM2.0×4.0 screws ❶ that secure the display hinge brackets to the display panel.
- b. Remove the display hinge brackets ❷.

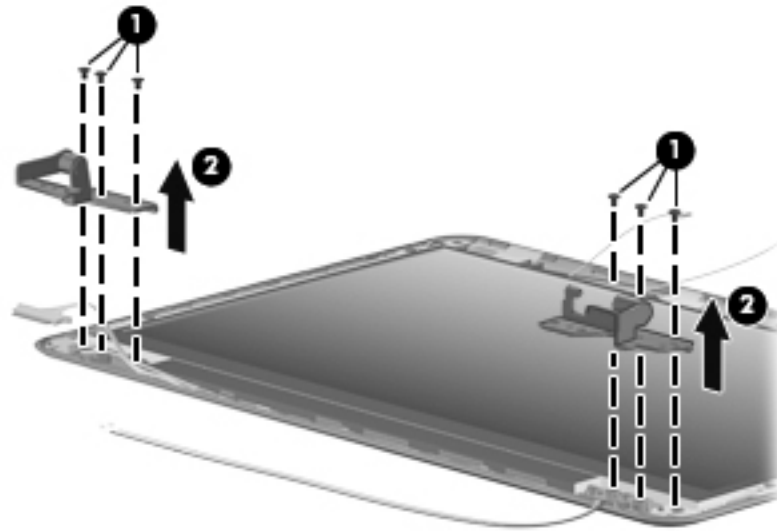

- c. Remove the 4 Phillips PM2.0×4.0 screws ❶ that secure the display panel to the display enclosure.
- d. Remove the display panel ❷.

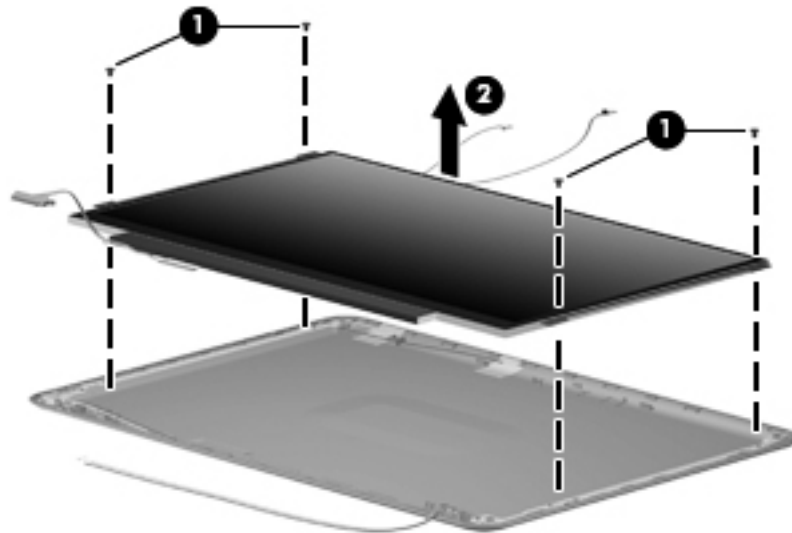

10. If it is necessary to replace the display panel/webcam/microphone cable:
 - a. Turn the display panel upside down, with the bottom edge toward you.
 - b. Lift the adhesive support strip ❶ that secures the display panel/webcam/microphone cable to the display panel.
 - c. Disconnect the display panel/webcam/microphone cable ❷ from the connector on the back of the display panel, and remove the display panel/webcam/microphone cable.

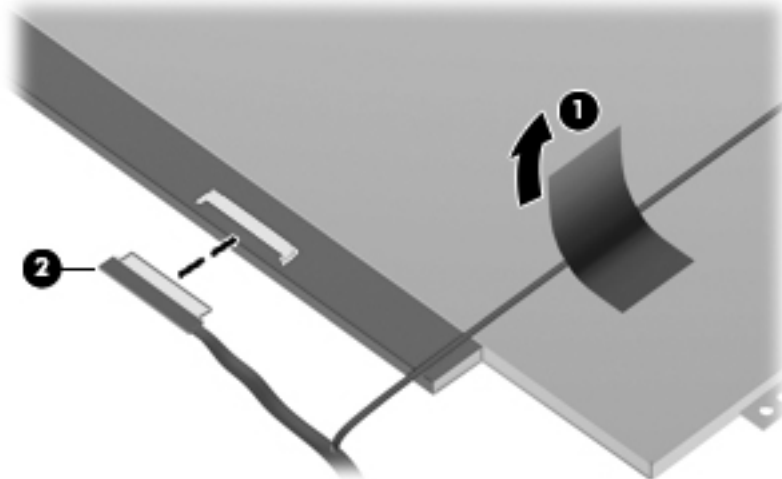

11. If it is necessary to replace the wireless antenna transceivers and cables:

- a. Detach the wireless antenna transceivers ❶ from the display enclosure. (The transceivers are attached to the enclosure with double-sided tape.)
- b. Release the wireless antenna cables ❷ from the clips and routing channel built into the left side of the display enclosure, and remove the wireless antenna transceivers and cables.

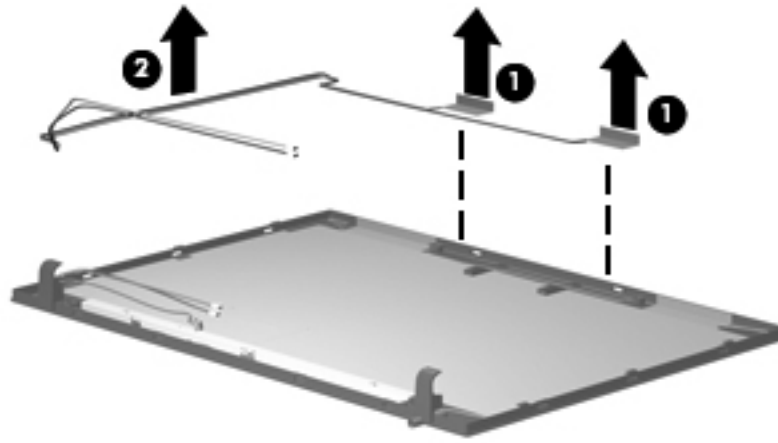

Reverse this procedure to reassemble and install the display assembly.

Multi board

Description	Spare part number
Multi board (includes USB and RJ-45 ports, and cable)	580066-001
Multi board for use the with the HP Pavilion (includes USB and RJ-45 ports, and cable)	591994-001

Before removing the multi board, follow these steps:

1. Shut down the computer. If you are unsure whether the computer is off or in Hibernation, turn the computer on, and then shut it down through the operating system.
2. Disconnect all external devices connected to the computer.
3. Disconnect the power from the computer by first unplugging the power cord from the AC outlet, and then unplugging the AC adapter from the computer.
4. Remove the battery (see [“Battery” on page 4-7](#)).
5. Remove the following components:
 - a. Accessory compartment cover (see [“WLAN module” on page 4-9](#))
 - b. Hard drive (see [“Hard drive” on page 4-18](#))
 - c. Keyboard (see [“Keyboard” on page 4-21](#))
 - d. Top cover (see [“Top cover” on page 4-24](#))
 - e. Display assembly (see [“Display assembly” on page 4-31](#))

Remove the multi board:

1. Disconnect the multi board cable ❶ from the system board.
2. Remove the 2 Phillips PM2.0×5.0 screws ❷ that secure the multi board to the base enclosure.
3. Remove the multi board ❸ and cable.

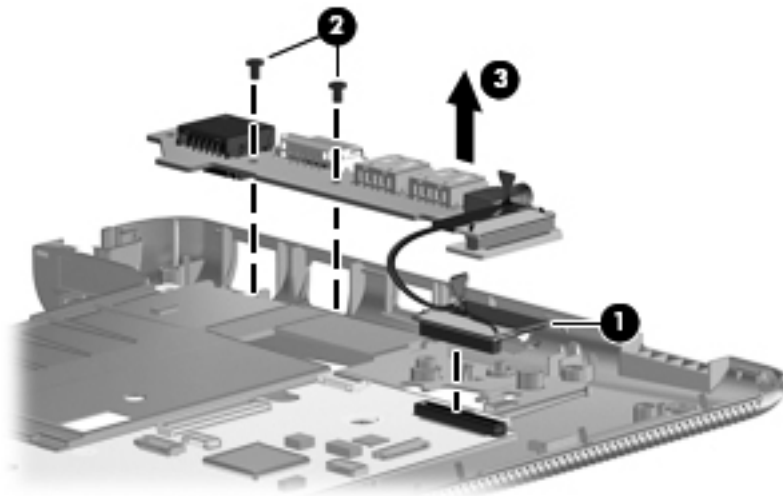

Reverse this procedure to install the multi board.

System board

Description	Spare part number
System board (includes processor, 1024-MB base memory, and replacement thermal material):	
Includes Intel Atom N280 1.66-GHz processor, 512-KB Level 2 cache, 667-MHz front-side bus (FSB) for use with the HP Mini and Compaq Mini	580000-001
Includes Intel Atom N270 1.6-GHz processor, 512-KB Level 2 cache, 533-MHz front-side bus (FSB) for use with the HP Mini and Compaq Mini	579999-001
Includes Intel Pentium 1.3-GHz processor, 2048-KB Level 2 cache, 800-MHz FSB for use with HP Pavilion	581751-001
Includes Intel Pentium 1.2-GHz processor, 1024-KB Level 2 cache, 800-MHz FSB for use with the HP Pavilion	581750-001

Before removing the system board, follow these steps:

1. Shut down the computer. If you are unsure whether the computer is off or in Hibernation, turn the computer on, and then shut it down through the operating system.
2. Disconnect all external devices connected to the computer.
3. Disconnect the power from the computer by first unplugging the power cord from the AC outlet, and then unplugging the AC adapter from the computer.
4. Remove the battery (see [“Battery” on page 4-7](#)).
5. Remove the following components:
 - a. Accessory compartment cover (see [“WLAN module” on page 4-9](#))
 - b. Hard drive (see [“Hard drive” on page 4-18](#))
 - c. Keyboard (see [“Keyboard” on page 4-21](#))
 - d. Top cover (see [“Top cover” on page 4-24](#))
 - e. Display assembly (see [“Display assembly” on page 4-31](#))

When replacing the system board, be sure that the following additional components are removed from the defective system board and installed on the replacement system board:

- SIM (see [“SIM” on page 4-8](#))
- WLAN module (see [“WLAN module” on page 4-9](#))
- RTC battery (see [“RTC battery” on page 4-15](#))
- Expansion memory module (see [“Expansion memory module” on page 4-16](#))
- WWAN module (see [“WWAN module” on page 4-13](#))
- Power connector (see [“Power connector” on page 4-41](#))
- Fan (see [“Fan” on page 4-42](#))
- Heat sink (see [“Heat sink assembly” on page 4-43](#))

Remove the system board:

1. Remove the Phillips PM2.0×7.0 screw ❶ that secures the power connector to the base enclosure.
2. Release the power connector ❷ from the base enclosure.

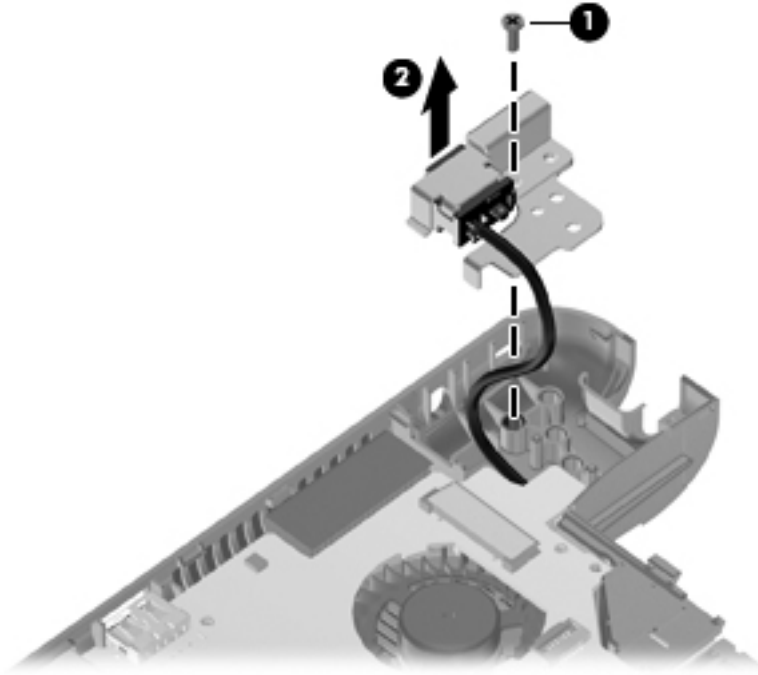

3. Remove the Phillips PM2.0×4.0 screw that secures the system board to the base enclosure.

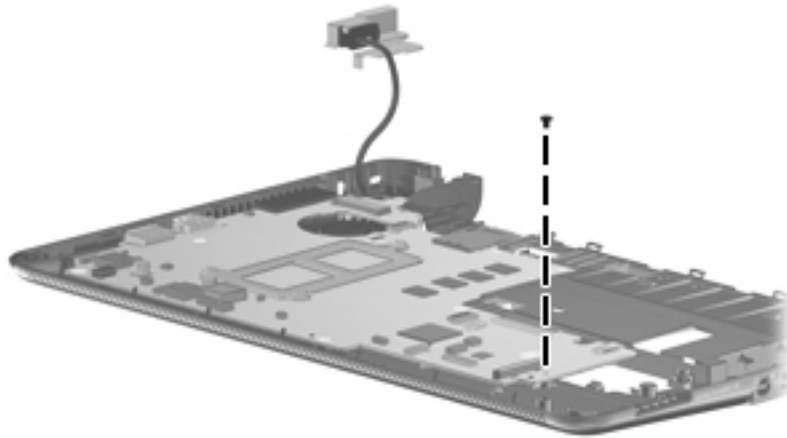

4. Lift the right side of the system board ❶ until it rests at an angle.
5. Remove the system board ❷ by sliding it away from the base enclosure at an angle.

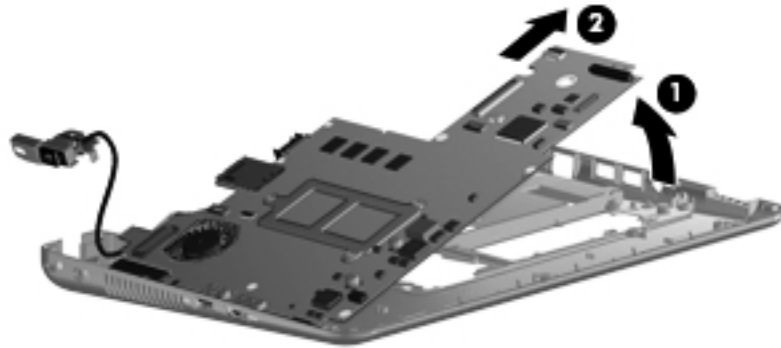

Reverse this procedure to install the system board.

Power connector

Description	Spare part number
Power connector (includes cable)	591851-001

Before removing the power connector, follow these steps:

1. Shut down the computer. If you are unsure whether the computer is off or in Hibernation, turn the computer on, and then shut it down through the operating system.
2. Disconnect all external devices connected to the computer.
3. Disconnect the power from the computer by first unplugging the power cord from the AC outlet, and then unplugging the AC adapter from the computer.
4. Remove the battery (see [“Battery” on page 4-7](#)).
5. Remove the following components:
 - a. Accessory compartment cover (see [“Keyboard” on page 4-21](#))
 - b. Hard drive (see [“Hard drive” on page 4-18](#))
 - c. Keyboard (see [“Keyboard” on page 4-21](#))
 - d. Top cover (see [“Top cover” on page 4-24](#))
 - e. Display assembly (see [“Display assembly” on page 4-31](#))
 - f. System board (see [“System board” on page 4-38](#))

Remove the power connector:

1. Disconnect the power connector cable from the system board.
2. Remove the power connector.

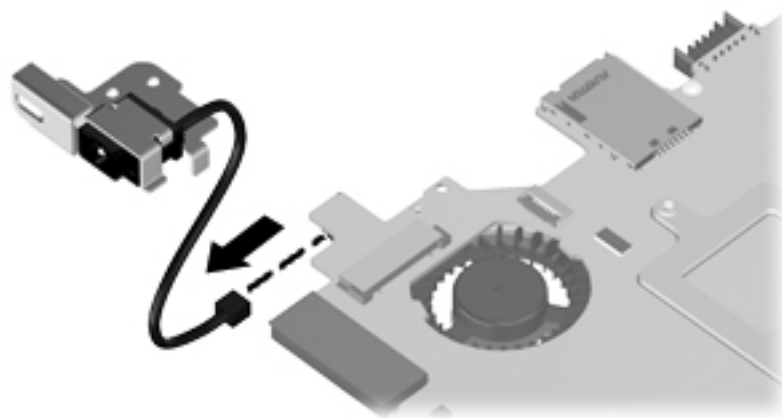

Reverse this procedure to install the power connector.

Fan

Description	Spare part number
Fan (includes cable)	580061-001

Before removing the fan, follow these steps:

1. Shut down the computer. If you are unsure whether the computer is off or in Hibernation, turn the computer on, and then shut it down through the operating system.
2. Disconnect all external devices connected to the computer.
3. Disconnect the power from the computer by first unplugging the power cord from the AC outlet, and then unplugging the AC adapter from the computer.
4. Remove the battery (see [“Battery” on page 4-7](#)).
5. Remove the following components:
 - a. Accessory compartment cover (see [“Keyboard” on page 4-21](#))
 - b. Hard drive (see [“Hard drive” on page 4-18](#))
 - c. Keyboard (see [“Keyboard” on page 4-21](#))
 - d. Top cover (see [“Top cover” on page 4-24](#))
 - e. Display assembly (see [“Display assembly” on page 4-31](#))
 - f. System board (see [“System board” on page 4-38](#))

Remove the fan:

1. Disconnect the fan cable ❶ from the system board.
2. Remove the 2 Phillips PM2.0×4.0 screws ❷ that secure the fan to the system board.
3. Remove the fan ❸.

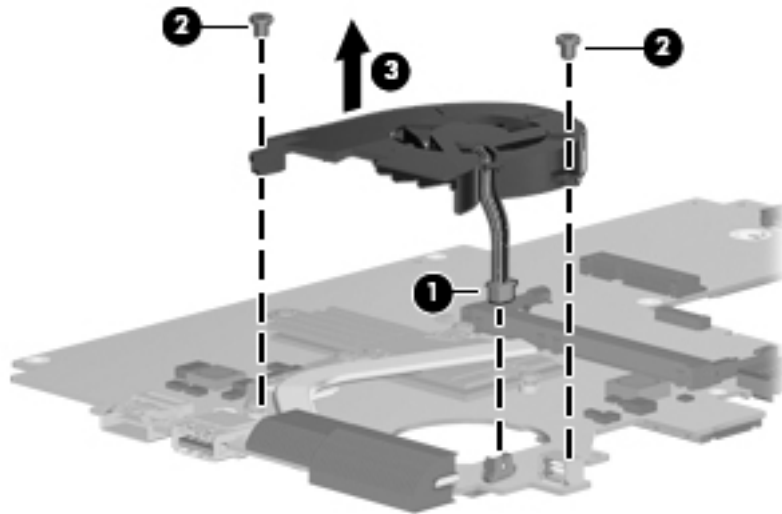

Reverse this procedure to install the fan.

Heat sink assembly



To properly ventilate the computer, allow at least 7.6 cm (3 in) of clearance on the left side of the computer. The computer uses an electric fan for ventilation. The fan is controlled by a temperature sensor and is designed to turn on automatically when high temperature conditions exist. These conditions are affected by high external temperatures, system power consumption, power management/battery conservation configurations, battery fast charging, and software requirements. Exhaust air is displaced through the ventilation grill located on the left side of the computer.

Description	Spare part number
Heat sink assembly (includes replacement thermal material)	
For use with the HP Mini and Compaq Mini	580059-001
For use with the HP Pavilion	580058-001

Before removing the heat sink assembly, follow these steps:

1. Shut down the computer. If you are unsure whether the computer is off or in Hibernation, turn the computer on, and then shut it down through the operating system.
2. Disconnect all external devices connected to the computer.
3. Disconnect the power from the computer by first unplugging the power cord from the AC outlet, and then unplugging the AC adapter from the computer.
4. Remove the battery (see [“Battery” on page 4-7](#)).
5. Remove the following components:
 - a. Accessory compartment cover (see [“Keyboard” on page 4-21](#))
 - b. Hard drive (see [“Hard drive” on page 4-18](#))
 - c. Keyboard (see [“Keyboard” on page 4-21](#))
 - d. Top cover (see [“Top cover” on page 4-24](#))
 - e. Display assembly (see [“Display assembly” on page 4-31](#))
 - f. System board (see [“System board” on page 4-38](#))
 - g. Fan (see [“Fan” on page 4-42](#))

Remove the heat sink assembly:

1. Following the 1, 2, 3, 4, 5 sequence stamped into the heat sink assembly, loosen the 5 Phillips PM2.0×6.0 captive screws ❶ that secure the fan and heat sink assembly to the system board.

 Due to the adhesive quality of the thermal material located between the heat sink and system board components, it may be necessary to move the heat sink from side to side to detach it.

 Step 2 applies to HP Mini and Compaq Mini computer models. See Step 3 for HP Pavilion computer models.

2. Remove the heat sink assembly ❷.

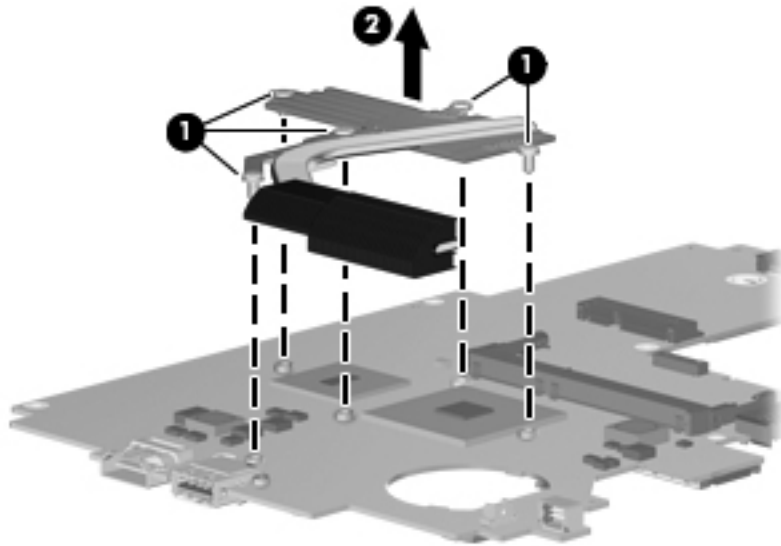

 The thermal material must be thoroughly cleaned from the surfaces of the heat sink and the system board each time the fan and heat sink are removed:

- Thermal paste is used on the processor ❶ and the heat sink section ❷ that services it.
 - Thermal pads are used on the MCP79 chip ❸ and the heat sink section ❹ that services it.
- Replacement thermal material is included with all system board and heat sink assembly spare part kits.

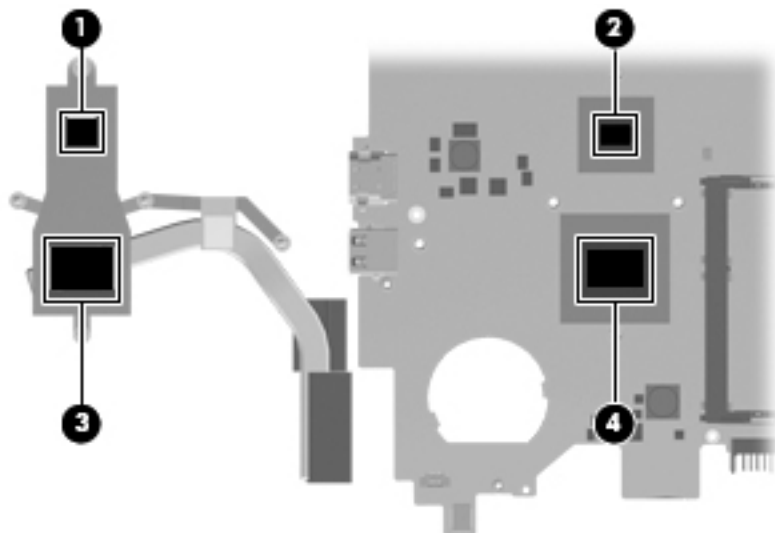



Step 3 applies to HP Pavilion computer models. See Step 2 for HP Mini and Compaq Mini Computer models.

3. Remove the heat sink assembly ②.

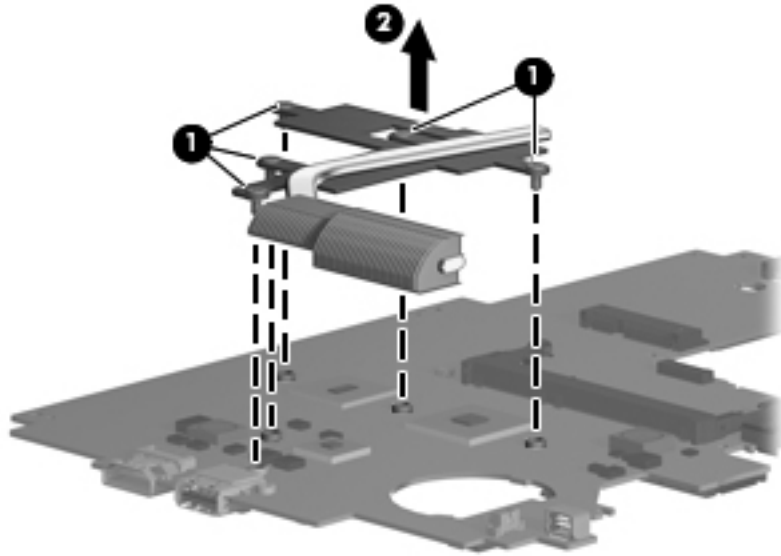

The thermal material must be thoroughly cleaned from the surfaces of the heat sink and the system board each time the fan and heat sink are removed:

- Thermal paste is used on the processor ① and the heat sink section ② that services it.
 - Thermal pads are used on the Intel GS45 (8W) chip ③ and the heat sink section ④ that services it.
 - Thermal pads are used on the Southbridge ICH9M chip ⑤ and the heat sink section ⑥ that services it.
- Replacement thermal material is included with all system board and heat sink assembly spare part kits.

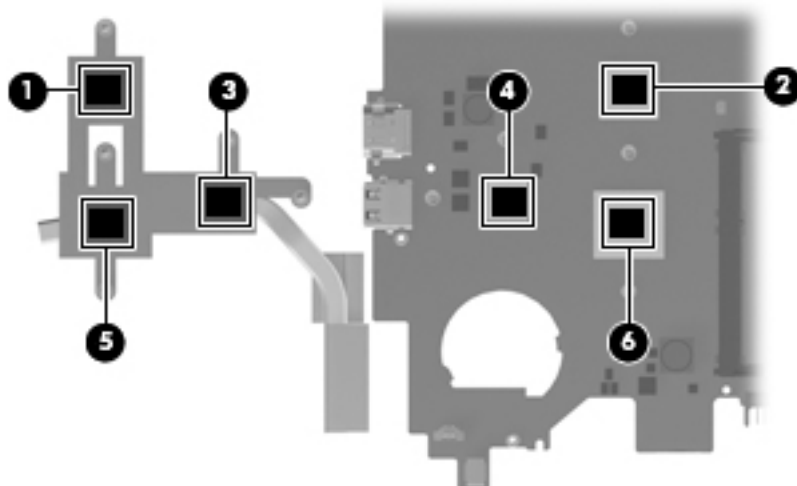

Reverse this procedure to install heat sink.

Starting Setup Utility

Setup Utility is a ROM-based information and customization utility that can be used even when your operating system is not working.

The utility reports information about the computer and provides settings for startup, security, and other preferences.

To start Setup Utility:

- » Open Setup Utility by turning on or restarting the computer, and then pressing **esc** while the “Press The ESC Key for Startup Menu” message is displayed in the lower-left corner of the screen.

Using Setup Utility

Changing the language of Setup Utility

The following procedure explains how to change the language of Setup Utility. If Setup Utility is not already running, begin at step 1. If Setup Utility is already running, begin at step 2.

1. Open Setup Utility by turning on or restarting the computer, and then pressing **f10** while the “F10 = BIOS Setup Options” message is displayed in the lower-left corner of the screen.
2. Use the arrow keys to select **System Configuration > Language**, and then press **enter**.
3. Use the arrow keys to select a language, and then press **enter**.
4. When a confirmation prompt with your language selected is displayed, press **enter**.
5. To save your change and exit Setup Utility, use the arrow keys to select **Exit > Exit Saving Changes**, and then press **enter**.

Your change goes into effect immediately.

Navigating and selecting in Setup Utility

Because Setup Utility is not operating system-based, it does not support the TouchPad. Navigation and selection are by keystroke.

- To choose a menu or a menu item, use the arrow keys.
- To choose an item in a list or to toggle a field, for example an Enable/Disable field, use either the arrow keys or **f5** or **f6**.
- To select an item, press **enter**.
- To close a text box or return to the menu display, press **esc**.
- To display additional navigation and selection information while Setup Utility is open, press **f1**.

Displaying system information

The following procedure explains how to display system information in Setup Utility. If Setup Utility is not open, begin at step 1. If Setup Utility is open, begin at step 2.

1. Open Setup Utility by turning on or restarting the computer, and then pressing **f10** while the “F10 = BIOS Setup Options” message is displayed in the lower-left corner of the screen.
2. Select the **Main** menu. System information such as the system time and date, and identification information about the computer is displayed.
3. To exit Setup Utility without changing any settings, use the arrow keys to select **Exit > Exit Discarding Changes**, and then press **enter**.

Restoring factory settings in Setup Utility

The following procedure explains how to restore the Setup Utility default settings. If Setup Utility is not already running, begin at step 1. If Setup Utility is already running, begin at step 2.

1. Open Setup Utility by turning on or restarting the computer, and then pressing **f10** while the “F10 = BIOS Setup Options” message is displayed in the lower-left corner of the screen.
2. Use the arrow keys to select **Exit > Load Setup Defaults**, and then press **enter**.
3. When the Setup Confirmation is displayed, press **enter**.
4. To save your change and exit Setup Utility, use the arrow keys to select **Exit > Exit Saving Changes**, and then press **enter**.

The Setup Utility default settings go into effect when the computer restarts.



Your password settings, language settings, security settings, and hard drive mode are not changed when you restore the factory settings.

Exiting Setup Utility

You can exit Setup Utility with or without saving changes.

- To exit Setup Utility and save your changes from the current session:

If the Setup Utility menus are not visible, press **esc** to return to the menu display. Then use the arrow keys to select **Exit > Exit Saving Changes**, and then press **enter**.

- To exit Setup Utility without saving your changes from the current session:

If the Setup Utility menus are not visible, press **esc** to return to the menu display. Then use the arrow keys to select **Exit > Exit Discarding Changes**, and then press **enter**.

After either choice, the computer restarts in your operating system.

Setup Utility menus

The menu tables in this section provide an overview of Setup Utility options.



Some of the Setup Utility menu items listed in this chapter may not be supported by your computer.

Main menu

Select	To do this
System Information	<ul style="list-style-type: none"> ■ View and change the system time and date. ■ View identification information about the computer. ■ View specification information about the processor, memory size, and system BIOS.

Security menu

Select	To do this
Administrator Password	Enter, change, or delete an administrator password.
Power-On Password	Enter, change, or delete a power-on password.

Diagnostics menu

Select	To do this
Primary Hard Disk Self Test (select models only)	Run a comprehensive self-test on the hard drive.
Memory test	Run a diagnostic test on the system memory.

System Configuration menu

Select	To do this
Language support	Change the Setup Utility language.
Virtualization Technology (select models only)	Enable/disable Virtualization Technology.
LAN power saving	Enable/disable the LAN power saving option.
Boot Options	<p>Set the following boot options:</p> <ul style="list-style-type: none">■ POST (power-on self test) f10 and f12 Delay (sec.): Set the delay for the f10 and f12 functions of Setup Utility in intervals of 5 seconds each (0, 5, 10, 15, 20).■ CD-ROM Boot: Enable/disable boot from CD/DVD ROM drive.■ Floppy Boot: Enable/disable boot from diskette drive.■ Internal Network Adapter boot: Enable/disable boot from Internal Network Adapter.■ Boot order - Set the boot order for:<ul style="list-style-type: none"><input type="checkbox"/> Internal hard drive (select models only) <p> Internal hard drive boot capability is disabled if an exclamation mark is displayed.</p> <ul style="list-style-type: none"><input type="checkbox"/> USB Floppy<input type="checkbox"/> USB Hard drive<input type="checkbox"/> USB CD/DVD ROM Drive<input type="checkbox"/> Network adapter

Specifications

Computer specifications

	Metric	U.S.
Dimensions		
Length	22.78 cm	8.97 in
Width	32.49 cm	12.79 in
Height (front to back)	2.73 to 3.68 cm	1.07 to 1.45 in
Weight		
	1.9 kg	4.19 lbs
Input power		
Operating voltage	18.5Vdc @ 3.5A = 65W	
Operating current	3.5A	
Temperature		
Operating (not writing to optical disc)	0°C to 35°C	32°F to 95°F
Operating (writing to optical disc)	5°C to 35°C	41°F to 95°F
Nonoperating	-20°C to 60°C	-4°F to 140°F
Relative humidity		
Operating	10% to 90%	
Nonoperating	5% to 95%	
Maximum altitude (unpressurized)		
Operating	-15 m to 3,048 m	-50 ft to 10,000 ft
Nonoperating	-15 m to 12,192 m	-50 ft to 40,000 ft



Applicable product safety standards specify thermal limits for plastic surfaces. The computer operates well within this range of temperatures.

11.6-in display specifications

	Metric	U.S.
Dimensions		
Height	17.8 cm	7.0 in
Width	28.4 cm	11.2 in
Diagonal	33.6 cm	13.3 in
Number of colors	Up to 16.8 million	
Contrast ratio	400:1 (typical)	
Brightness	200 nits (typical)	
Pixel resolution		
Pitch	0.1875 × 0.1875 mm	
Format	1366 × 768	
Configuration	RGB vertical stripe	
Backlight	LED	
Character display	80 × 25	
Total power consumption	4.0 W	
Viewing angle	±40° horizontal, +120°/-40° vertical (typical)	

Hard drive specifications

	320-GB*	250-GB*	160-GB*
Dimensions			
Height	9.5 mm	9.5 mm	9.5 mm
Width	70 mm	70 mm	70 mm
Weight	101 g	101 g	101 g
Interface type			
SATA			
Transfer rate			
100 MB/sec			
Security			
ATA security			
Seek times (typical read, including setting)			
Single track	1.5 ms	2.0 ms	2.0 ms
Average	12.0 ms	12.0 ms	12.0 ms
Maximum	22.0 ms	22.0 ms	22.0 ms
Logical blocks			
625,142,448 488,397,168 312,581,808			
Disc rotational speed			
5400 rpm			
Operating temperature			
5°C to 55°C (41°F to 131°F)			

*1 GB = 1 billion bytes when referring to hard drive storage capacity. Actual accessible capacity is less. Actual drive specifications may differ slightly.

 Certain restrictions and exclusions apply. Contact technical support for details.

DVD±RW and CD-RW SuperMulti Double-Layer Combo Drive with LightScribe specifications

Applicable disc	Read:	Write:
	CD-DA, CD+(E)G, CD-MIDI, CD-TEXT, CD-ROM, CD-ROM XA, MIXED MODE CD, CD-I, CD-I Bridge (Photo-CD, Video CD), Multisession CD (Photo-CD, CD EXTRA, Portfolio, CD-R, CD-RW), CD-R, CD-RW, DVD-ROM (DVD-5, DVD-9, DVD-10, DVD-18), DVD-R, DVD-RW, DVD+R, DVD+RW, DVD-RAM	CD-R, CD-RW, DVD+R, DVD+RW, DVD-R, DVD-RW, DVD-RAM, LightScribe
Interface	SATA	
Access time	CD	DVD
Random	< 150 ms	< 160 ms
Max data transfer rate		
24X CD-ROM	3,600 KB/sec	
8X DVD-ROM	10,800 KB/sec	
24X CD-R	3,600 KB/sec	
16X CD-RW	2,400 KB/sec	
8X DVD+R	10,800 KB/sec	
8x DVD+RW	10,800 KB/sec	
8X DVD-R	10,800 KB/sec	
6X DVD-RW	8,100 KB/sec	
4X DVD-R Dual Layer	5,400 KB/sec	
4X DVD+R Dual Layer	5,400 KB/sec	
5X DVD-RAM	6,750 KB/sec	
Max media capacity (read)	8.5 GB	
Max media capacity (write)	8.5 GB	
Transport	Tray loading	

Blu-ray ROM with LightScribe DVD±R/RW SuperMulti Double-Layer Drive specifications

Applicable disc	Read:	Write:	
	CD-DA, CD+(E)G, CD-MIDI, CD-TEXT, CD-ROM, CD-ROM XA, MIXED MODE CD, CD-I, CD-I Bridge (Photo-CD, Video CD), Multisession CD (Photo-CD, CD-EXTRA, Portfolio, CD-R, CD-RW), CD-R, CD-RW, DVD-ROM (DVD-5, DVD-9, DVD-10, DVD-18), DVD-R, DVD-RW, DVD+R, DVD+RW, DVD-RAM, BD-ROM, BD-R, BD-RE	CD-R, CD-RW, DVD+R, DVD+R(9), DVD+RW, DVD-R, DVD-R(9), DVD-RW, DVD-RAM, LightScribe	
Interface	SATA		
Access time	CD	DVD	BD
Random	< 190 ms	< 190 ms	< 230 ms
Max data transfer rate			
24X CD-ROM	3,600 KB/sec		
8X DVD-ROM	10,800 KB/sec		
4X BD-ROM	18,000 KB/sec		
16X CD-R	1,200 KB/sec		
10X CD-RW	1,500 KB/sec		
8X DVD+R	10,800 KB/sec		
8X DVD+RW	10,800 KB/sec		
8X DVD-R	10,800 KB/sec		
6X DVD-RW	8,100 KB/sec		
4X DVD+R Dual Layer	5,400 KB/sec		
4X DVD-R Dual Layer	5,400 KB/sec		
5X DVD-RAM	6,750 KB/sec		
Max media capacity (read)	50.0 GB		
Max media capacity (write)	8.5 GB		
Transport	Tray loading		

System DMA specifications

Hardware	DMA System function
DMA0	Not applicable
DMA1*	Not applicable
DMA2*	Not applicable
DMA3	Not applicable
DMA4	Direct memory access controller
DMA5*	Not applicable
DMA6	Not assigned
DMA7	Not assigned

*ExpressCard controller can use DMA 1, 2, or 5.

System memory map specifications

Size	Memory address	System function
640 KB	00000000–0009FFFF	Base memory
128 KB	000A0000–000BFFFF	Video memory
64 KB	000C0000–000CFFFF	Video BIOS
64 KB	000E8000–000FFFFFF	System BIOS
	00100000–XFFFFFFF	Extended memory (based on memory installed)
	(X+1)0000000–FEDFFFFFF	PCI bus
	FED00000–FED003FF	High-precision event timer
	FEE01000–FFFFFFF	PCI bus

System interrupt specifications

Hardware IRQ	System function
IRQ0	System timer
IRQ1	Standard 101-/102-key or Microsoft® natural keyboard
IRQ8	System CMOS/real-time clock
IRQ12	Synaptics PS/2 TouchPad
IRQ13	Numeric data processor
IRQ16	Intel ICH9 family USB universal host controller 2937 Mobile Intel 4 Series express chipset family
IRQ17*	High-definition audio controller Intel ICH9 family USB universal host controller 2938 Marvell Yukon 88E8072 PCIE-gigabit Ethernet controller
IRQ18	Intel ICH9 family USB universal host controller 2939 Intel ICH9 family USB universal host controller 2936
IRQ19	Intel ICH9 family USB2 enhanced controller 293C
IRQ20	Intel ICH9 family USB2 enhanced controller 293A Intel ICH9 family USB universal host controller 2934
IRQ21	Intel ICH9M-E/M SATA AHCI controller
IRQ22	Intel ICH9 family USB universal host controller 2935

*Default configuration; other possible audio configurations are IRQ5, IRQ7, IRQ9, IRQ10, or none.

 ExpressCards may assert IRQ3, IRQ4, IRQ5, IRQ7, IRQ9, IRQ10, IRQ11, or IRQ15. Either the infrared or the serial port may assert IRQ3 or IRQ4.

 For operating systems after Windows 2000, APIC (Advanced programming interrupt controller) is used.

System I/O address specifications

I/O address (hex)	System function (shipping configuration)
000–01F	DMA controller
020–021	Program interrupt controller
024–025	Program interrupt controller
028–029	Program interrupt controller
02C–03D	Program interrupt controller
02E–02F	Motherboard resources
030–031	Program interrupt controller
034–035	Program interrupt controller
038–039	Program interrupt controller
03C–03D	Program interrupt controller
040–043	System timer
04E–04F	Motherboard resources
050–053	System timer
060	Standard 101-/102-key or Microsoft natural keyboard
061	Motherboard resources
062	Microsoft ACPI-compliant embedded controller
063	Motherboard resources
064	Standard 101-/102-key or Microsoft natural keyboard
065	Motherboard resources
066	Microsoft ACPI-compliant embedded controller
067	Motherboard resources
070	Motherboard resources
071–077	System CMOS/real-time clock
080	Motherboard resources
081–091	Direct memory access controller
092	Motherboard resources
093–09F	Direct memory access controller
0A0–0A1	Program interrupt controller
0A4–0A5	Program interrupt controller
0A8–0A9	Program interrupt controller
0AC–0AD	Program interrupt controller
0B0–0B1	Program interrupt controller
0B2–0B3	Motherboard resources
0B4–0B5	Program interrupt controller
0B8–0B9	Program interrupt controller
0BC–0BD	Program interrupt controller

(Continued)

I/O address (hex)	System function (shipping configuration)
0C0–0DF	Direct memory access controller
0F0–0F0	Numeric data processor
0200–027F	Motherboard resources
3B0–3BB	Mobile Intel 4 Series express chipset family
3C0–3DF	Mobile Intel 4 Series express chipset family
400–47F	Motherboard resources
4D0–4D1	Programmable interrupt controller
500–57F	Motherboard resources
1000–1003	Motherboard resources
1010–101F	Motherboard resources
2000–20FF	Marvell Yukon 88E8072 PCIE-gigabit Ethernet controller
2000–2FFF	ICH9 family PCI express root port6-294A
3000–4FFF	ICH9 family PCI express root port5-2948
5000–6FFF	ICH9 family PCI express root port3-2944
7000–701F	ICH9M-E/M SATA AHCI controller
7020–703F	ICH9 family USB universal host controller 2936
7040–705F	ICH9 family USB universal host controller 2935
7060–707F	ICH9 family USB universal host controller 2934
7080–709F	ICH9 family USB universal host controller 2939
70A0–70BF	ICH9 family USB universal host controller 2938
70C0–70DF	ICH9 family USB universal host controller 2937
70E0–70E7	ICH9M-E/M SATA AHCI controller
70E8–70EF	ICH9M-E/M SATA AHCI Controller
70F0–70F7	Mobile Intel 4 Series express chipset family
70F8–70FB	ICH9M-E/M SATA AHCI controller
70FC–70FF	ICH9M-E/M SATA AHCI controller
EF80–EF9F	Motherboard resources
FE00–FE0F	Motherboard resources
FE80–EF8F	Motherboard resources
FFFF	Motherboard resources

Screw listing

This chapter provides specification and reference information for the screws used in the computer. The screws listed in this chapter are available in the Screw Kit, spare part number 580063-001.

Phillips PM2.0×4.0 screw

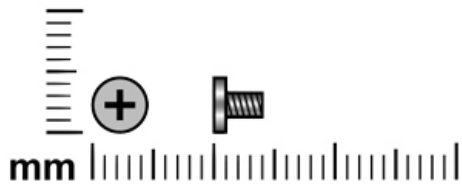

Color	Quantity	Length	Thread	Head diameter
Black	18	4.0 mm	2.0 mm	4.5 mm

Where used: One screw that secures the WLAN module to the system board

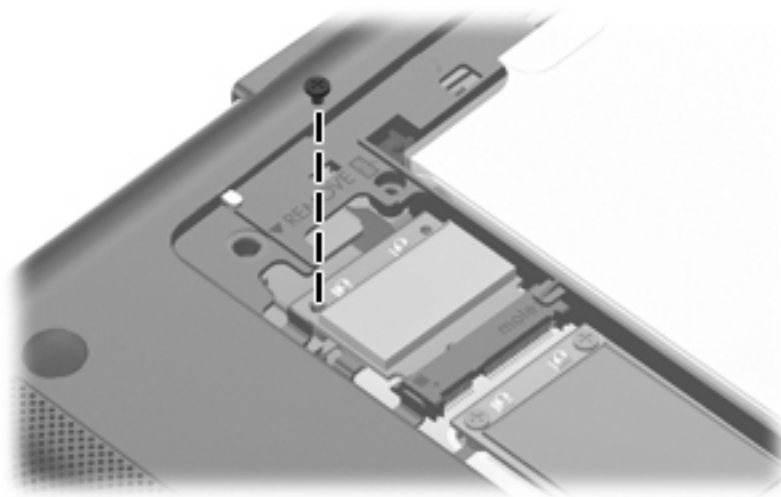

Where used: 2 screws that secure the WWAN module to the system board

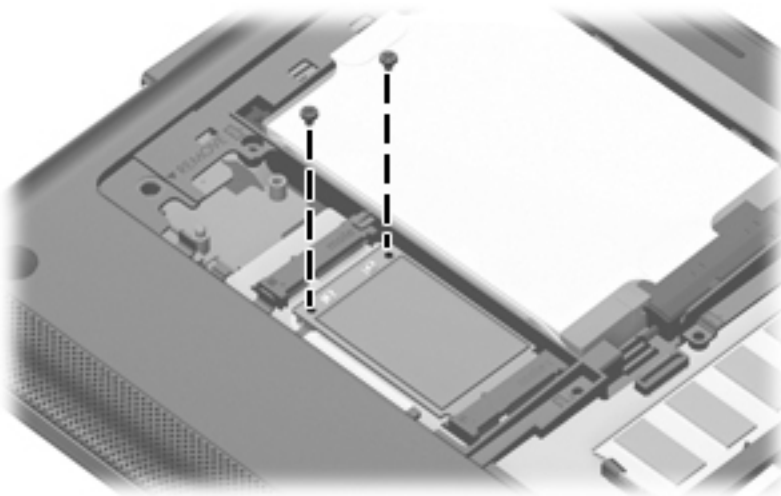

Where used: One screw that secures the wireless button board to the top cover

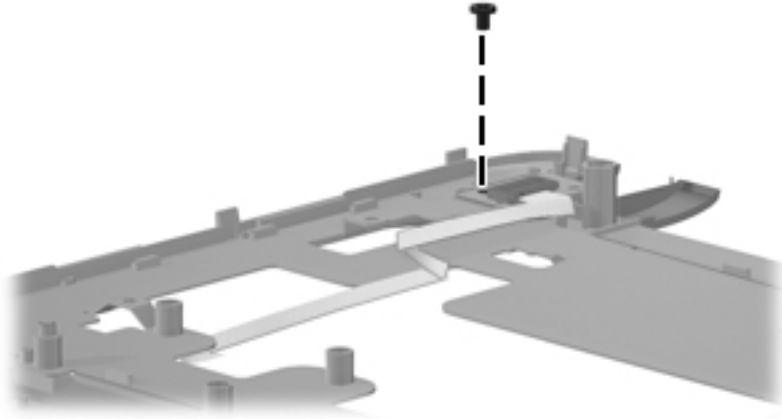

Where used: One screw that secures the power button board to the top cover

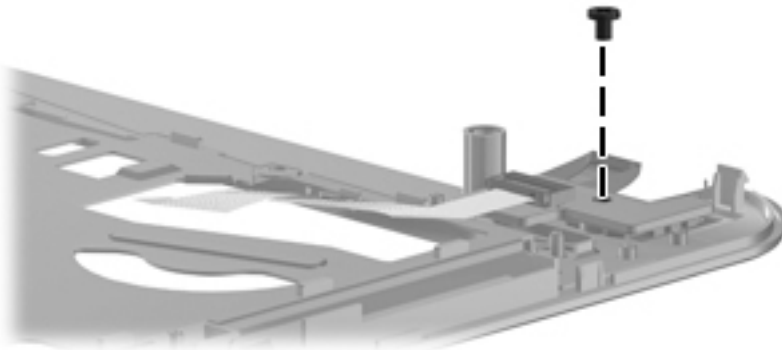

Where used: One screw that secures the digital media assembly to the base enclosure

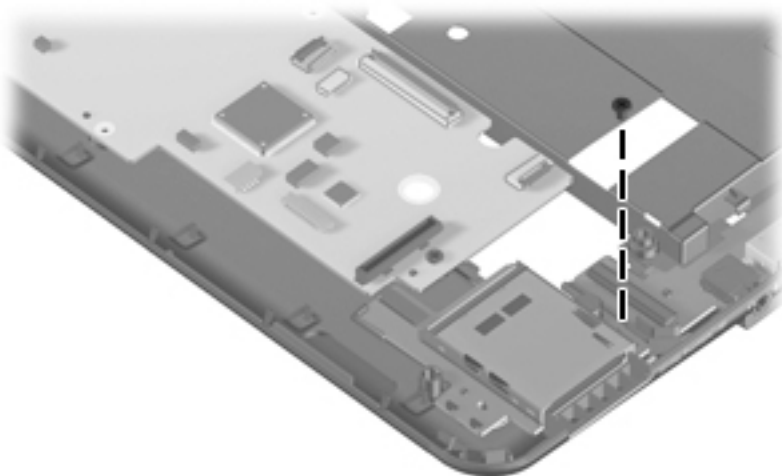

Where used: 6 screws that secure the display hinge brackets to the display enclosure

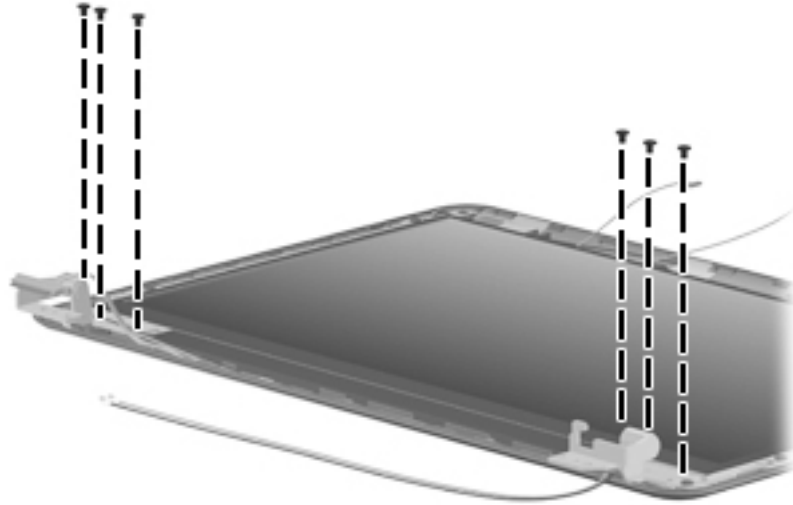

Where used: 4 screws that secure the display panel to the display enclosure

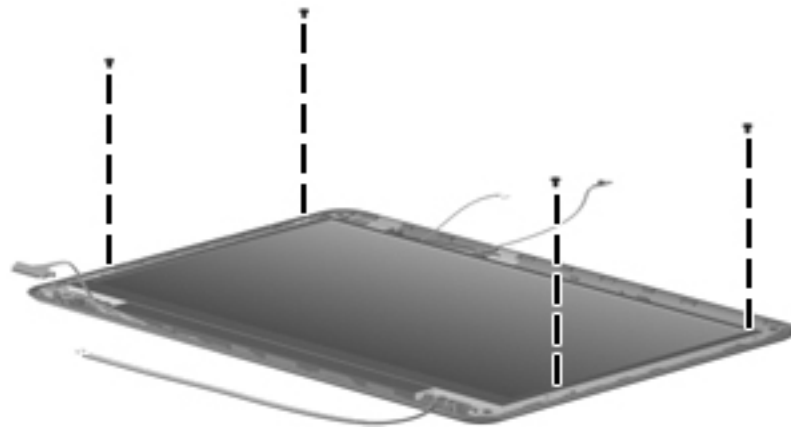

Where used: 2 screws that secure the fan to the system board (HP Mini and Compaq Mini models)

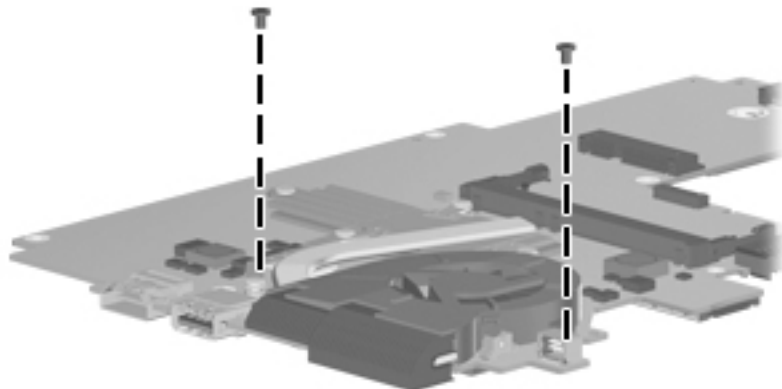

Where used: 2 screws that secure the fan to the system board (HP Pavilion models)

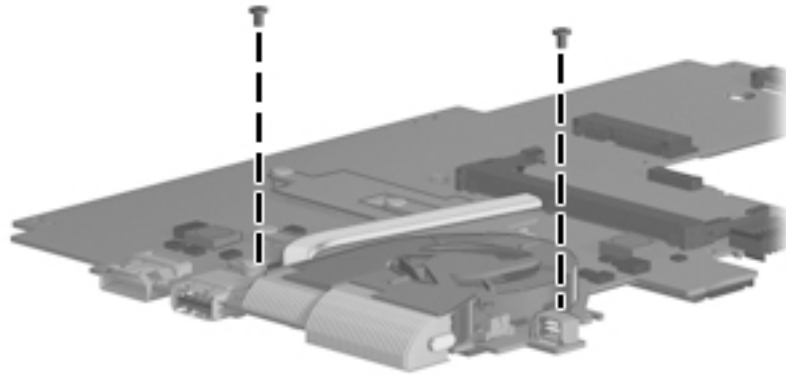

Phillips PM2.0×5.0 screw

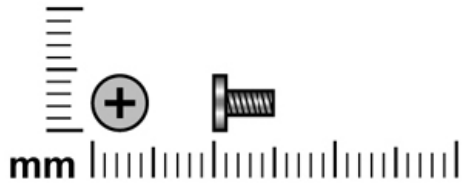

Color	Quantity	Length	Thread	Head diameter
Black	2	5.0 mm	2.0 mm	4.5 mm

Where used: 2 screws that secure the multi board to the base enclosure

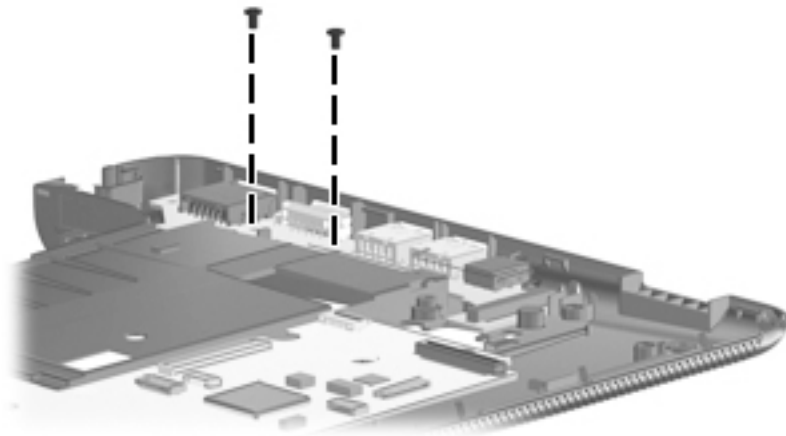

Phillips PM2.0×6.0 captive screw

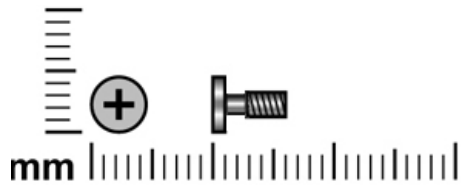

Color	Quantity	Length	Thread	Head diameter
Black	7	6.0 mm	2.0 mm	5.0 mm

Where used: 2 captive screws that secure the accessory compartment cover to the computer (screws are secured to the cover by C-clips)



Where used: 5 captive screws that secure the heat sink to the system board (screws are secured to the heat sink by C-clips) (HP Mini and Compaq Mini models)

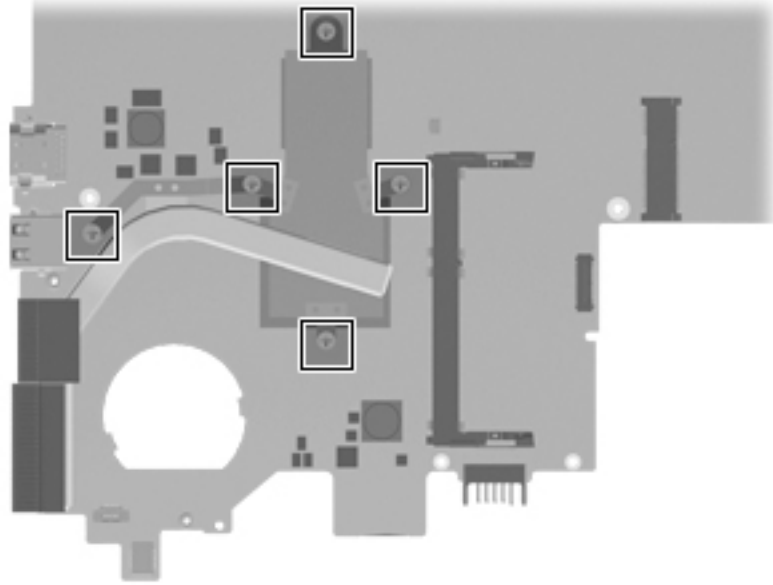

Where used: 5 captive screws that secure the heat sink to the system board (screws are secured to the heat sink by C-clips) (HP Pavilion models)

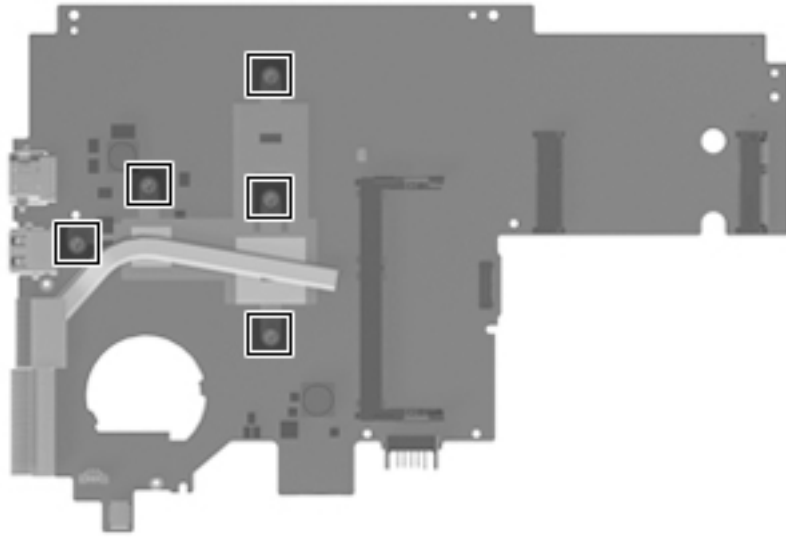

Phillips PM2.0×7.0 screw

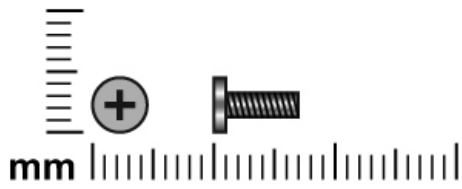

Color	Quantity	Length	Thread	Head diameter
Black	19	7.0 mm	2.0 mm	4.5 mm

Where used: 4 screws that secure the keyboard to the base enclosure

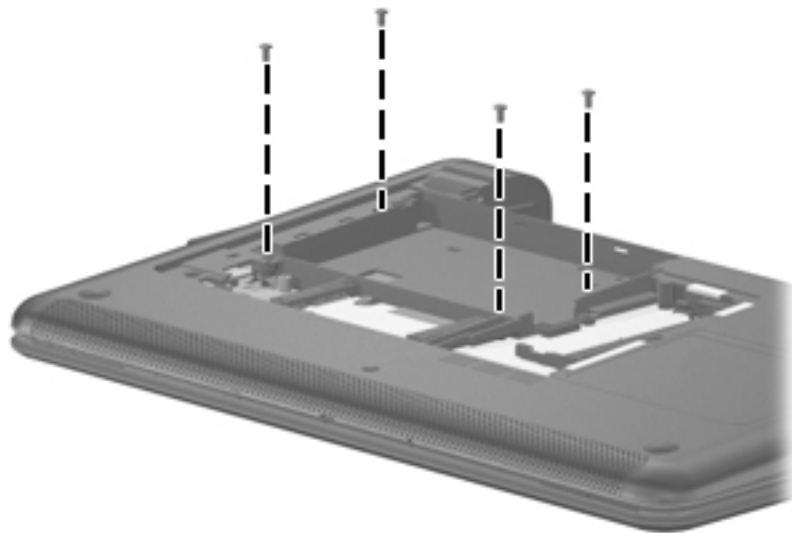

Where used: 3 screws that secure the top cover to the base enclosure

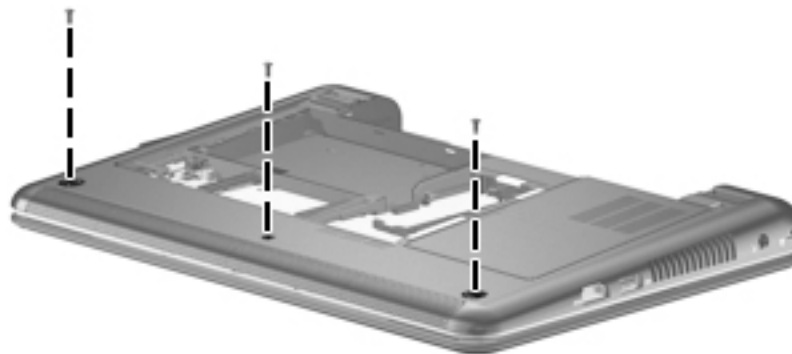

Where used: 4 screws that secure the top cover to the base enclosure

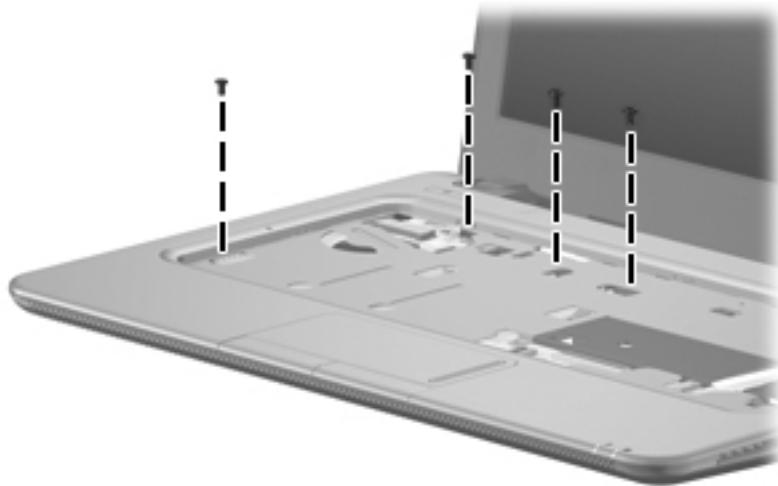

Where used: 2 screws that secure the speaker assembly to the base enclosure

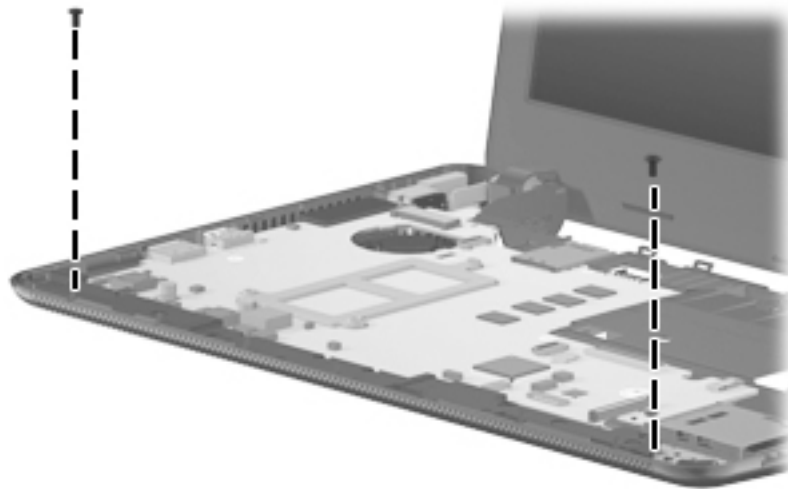

Where used: 4 screws that secure the display assembly to the base enclosure



Where used: One screw that secures the power connector to the base enclosure

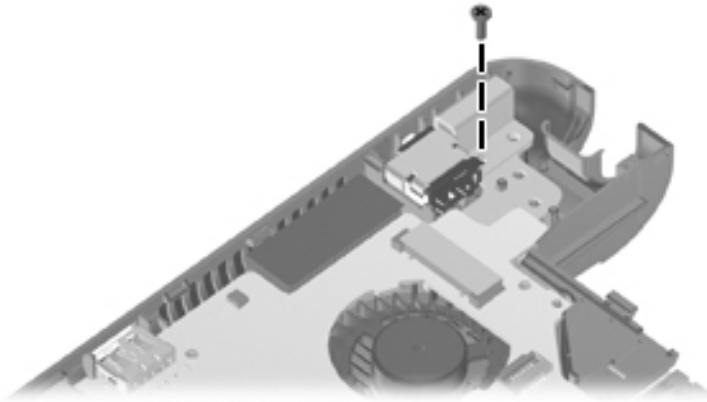

Where used: 1 screw that secures the system board to the base enclosure

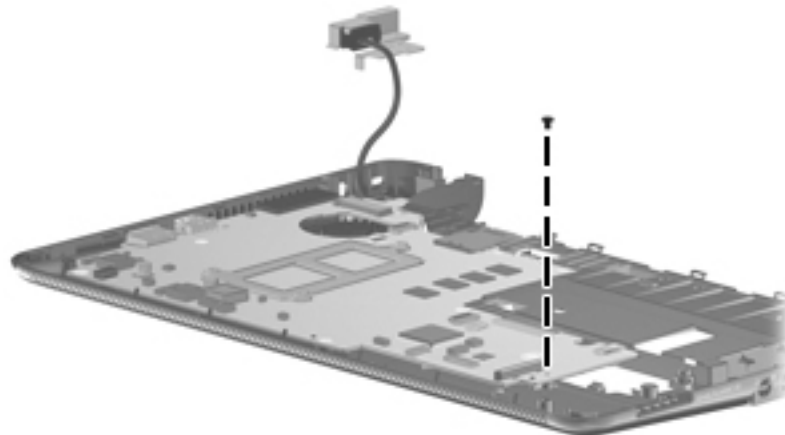

Phillips PM2.0×12.0 screw

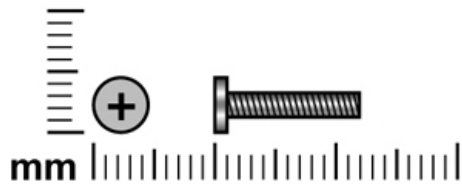

Color	Quantity	Length	Thread	Head diameter
Black	2	12.0 mm	2.0 mm	5.0 mm

Where used: 2 screws that secure the top cover to the base enclosure

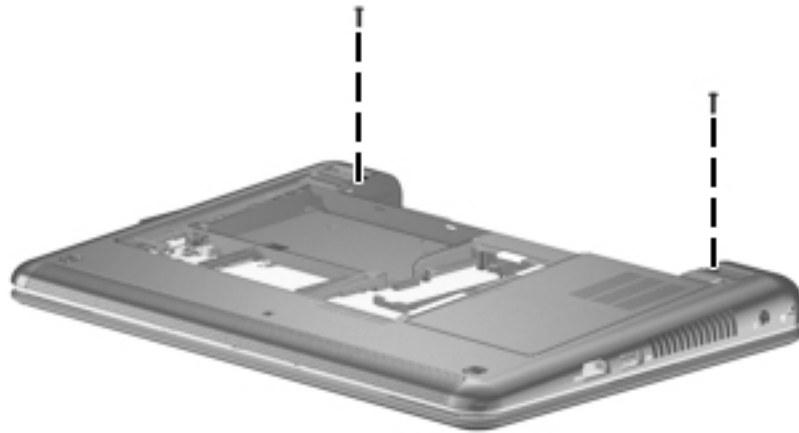

Phillips PM3.0×4.0 screw

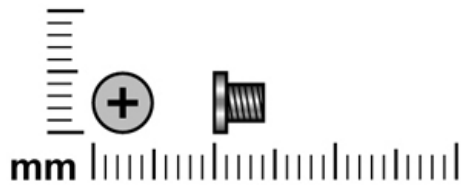

Color	Quantity	Length	Thread	Head diameter
Silver	4	4.0 mm	3.0 mm	5.0 mm

Where used: 4 screws that secure the hard drive bracket to the hard drive



Backup and recovery

Backup and recovery in Windows 7

Overview

Recovery after a system failure is as complete as your most current backup. HP recommends that you create recovery discs immediately after software setup. As you add new software and data files, you should continue to back up your system on a regular basis to maintain a reasonably current backup.

Tools provided by the operating system and HP Recovery Manager software are designed to help you with the following tasks for safeguarding your information and restoring it in case of a system failure:

- Creating a set of recovery discs (Recovery Manager software feature). Recovery discs are used to start up (boot) your computer and restore the operating system and software programs to factory settings in case of system failure or instability.
- Backing up your information regularly to protect your important system files.
- Creating system restore points (operating system feature). System restore points allow you to reverse undesirable changes to your computer by restoring the computer to an earlier state.
- Recovering a program or driver (Recovery Manager software feature). This feature helps you reinstall a program or driver without performing a full system recovery.
- Performing a full system recovery (Recovery Manager software feature). With Recovery Manager, you can recover your full factory image if you experience system failure or instability. Recovery Manager works from a dedicated recovery partition (select models only) on the hard drive or from recovery discs you create.



Computers with a solid-state drive (SSD) may not have a recovery partition. Recovery discs have been included for computers that do not have a partition. Use these discs to recover your operating system and software. To check for the presence of a recovery partition, select **Start**, right-click **Computer**, click **Manage**, and then click **Disk Management**. If the partition is present, an HP Recovery drive is listed in the window.

Creating recovery discs

HP recommends that you create recovery discs to be sure that you can restore your system to its original factory state if you experience serious system failure or instability. Create these discs after setting up the computer for the first time.

Handle these discs carefully and keep them in a safe place. The software allows the creation of only one set of recovery discs.



If your computer does not include an internal optical drive, you can use an optional external optical drive (purchased separately) to create recovery discs, or you can purchase recovery discs for your computer from the HP Web site.

Note the following guidelines before creating recovery discs:

- You will need high-quality DVD-R, DVD+R, BD-R (writable Blu-ray), or CD-R discs. All these discs are purchased separately. DVDs and BDs have a much higher capacity than CDs. If you use CDs, up to 20 discs may be required, whereas only a few DVDs or BDs are required.
 -  Read-write discs, such as CD-RW, DVD±RW, double-layer DVD±RW, and BD-RE (rewritable Blu-ray) discs, are not compatible with the Recovery Manager software.
- The computer must be connected to AC power during this process.
- Only one set of recovery discs can be created per computer.
- Number each disc before inserting it into the optical drive.
- If necessary, you can exit the program before you have finished creating the recovery discs. The next time you open Recovery Manager, you will be prompted to continue the disc creation process.

To create a set of recovery discs:

1. Select **Start > All Programs > Recovery Manager > Recovery Disc Creation**.
2. Follow the on-screen instructions.

Backing up your information

As you add new software and data files, you should back up your system on a regular basis to maintain a reasonably current backup. Back up your system at the following times:

- At regularly scheduled times
 -  Set reminders to back up your information periodically.
- Before the computer is repaired or restored
- Before you add or modify hardware or software

Note the following when backing up:

- Create system restore points using the Windows® System Restore feature, and periodically copy them to disc.
- Store personal files in the Documents library and back up this folder periodically.
- Back up templates stored in their associated programs.
- Save customized settings in a window, toolbar, or menu bar by taking a screen shot of your settings. The screen shot can be a time-saver if you have to reset your preferences.

To copy the screen and paste it into a word-processing document, follow these steps:

1. Display the screen.
2. Copy the screen:

To copy only the active window, press **alt+fn+prt sc**.

To copy the entire screen, press **fn+prt sc**.

3. Open a word-processing document, and then select **Edit > Paste**.
4. Save the document.

- You can back up your information to an optional external hard drive, a network drive, or discs.
- When backing up to discs, use any of the following types of discs (purchased separately): CD-R, CD-RW, DVD+R, DVD-R, or DVD±RW. The discs you use will depend on the type of optical drive installed in your computer.
 -  DVDs store more information than CDs, so using them for backup reduces the number of recovery discs required.
- When backing up to discs, number each disc before inserting it into the optical drive of the computer.

Using Windows Backup and Restore

To create a backup using Windows Backup and Restore, follow these steps:



Be sure that the computer is connected to AC power before you start the backup process.



The backup process may take over an hour, depending on file size and the speed of the computer.

1. Select **Start > All Programs > Maintenance > Backup and Restore**.
2. Follow the on-screen instructions to set up and create a backup.



Windows includes the User Account Control feature to improve the security of your computer.



You may be prompted for your permission or password for tasks such as installing software, running utilities, or changing Windows settings. Refer to Help and Support for more information.

Using system restore points

When you back up your system, you are creating a system restore point. A system restore point allows you to save and name a snapshot of your hard drive at a specific point in time. You can then recover back to that point if you want to reverse subsequent changes made to your system.



Recovering to an earlier restore point does not affect data files saved or e-mails created since the last restore point.

You also can create additional restore points to provide increased protection for your system files and settings.

When to create restore points

- Before you add or extensively modify software or hardware
- Periodically, whenever the system is performing optimally



If you revert to a restore point and then change your mind, you can reverse the restoration.

Create a system restore point

1. Select **Start > Control Panel > System and Security > System**.
2. In the left pane, click **System Protection**.
3. Click the **System Protection** tab.
4. Under Protection Settings, select the disk for which you want to create a restore point.
5. Click **Create**.
6. Follow the on-screen instructions.

Restore to a previous date or time

To revert to a restore point (created at a previous date and time), when the computer was functioning optimally, follow these steps:

1. Select **Start > Control Panel > System and Security > System**.
2. In the left pane, click **System protection**.
3. Click the **System Protection** tab.
4. Click **System Restore**.
5. Follow the on-screen instructions.

Performing a recovery



You can recover only files that you have previously backed up. HP recommends that you use HP Recovery Manager to create a set of recovery discs (entire drive backup) as soon as you set up your computer.

Recovery Manager software allows you to repair or restore the system if you experience system failure or instability. Recovery Manager works from recovery discs or from a dedicated recovery partition (select models only) on the hard drive. However, if your computer includes a solid-state drive (SSD), you may not have a recovery partition. If that is the case, recovery discs have been included with your computer. Use these discs to recover your operating system and software.



Windows has its own built-in repair features, such as System Restore. If you have not already tried these features, try them before using Recovery Manager.



Recovery Manager recovers only software that was preinstalled at the factory. Software not provided with this computer must be downloaded from the manufacturer's Web site or reinstalled from the disc provided by the manufacturer.

Recovering from the recovery discs

To restore the system from the recovery discs:

1. Back up all personal files.
2. Insert the first recovery disc into the optical drive and restart the computer.
3. Follow the on-screen instructions.

Recovering from the dedicated recovery partition (select models only)



Computers with an SSD may not have a recovery partition. If the computer does not have a recovery partition, you will not be able to recover using this procedure. Recovery discs have been included for computers that do not have a partition. Use these discs to recover your operating system and software.

On some models, you can perform a recovery from the partition on the hard drive, accessed by pressing either the **Start** button or **f11**. This restores the computer to its factory condition.

To restore the system from the partition, follow these steps:

1. Access Recovery Manager in either of the following ways:

Select **Start > All Programs > Recovery Manager > Recovery Manager**.

– or –

Turn on or restart the computer, and then press **esc** while the “Press the ESC key for Startup Menu” message is displayed at the bottom of the screen. Then, press **f11** while the “Press <F11> for recovery” message is displayed on the screen.

2. Click **System Recovery** in the Recovery Manager window.
3. Follow the on-screen instructions.

Backup and recovery in Windows XP

Overview

To protect your information, use the Windows Backup utility (select models only) to back up files and folders or create recovery points. In case of system failure, you can use the backup files to restore your computer.

Windows provides the following options:

- Backing up individual files and folders
- Backing up all files and folders
- Scheduling automatic backups
- Creating recovery points
- Recovering information



For detailed instructions, perform a search for these topics in Help and Support.

In case of system instability, HP recommends that you print the recovery procedures and save them for later use.

Backing up your information

Recovery after a system failure is as complete as your most current backup. You should create your initial backup immediately after software setup. As you add new software and data files, you should continue to back up your system on a regular basis to maintain a reasonably current backup.

You can back up individual files or folders to an optional external hard drive or to a network drive.

Note the following when backing up:

- Store personal files in the My Documents folder, and back it up periodically.
- Back up templates stored in their associated programs.

- Save customized settings that appear in a window, toolbar, or menu bar by taking a screen shot of your settings. The screen shot can be a time saver if you have to reset your preferences.

To copy the screen and paste it into a word-processing document:

- a. Display the screen you want to save.
- b. Copy the screen image:
 - To copy only the active window, press **alt+fn+prt sc**.
 - To copy the entire screen, press **fn+prt sc**.
- c. Open a word-processing document, and then select **Edit > Paste**.
 - The screen image is added to the document.
- d. Save the document.

To create a backup using the Windows Backup utility (select models only), follow these steps:



Be sure that the computer is connected to AC power before you start the backup process.

The backup process may take over an hour, depending on file size and the speed of the computer.

1. Select **Start > All Programs > Accessories > System Tools > Backup**.
2. Follow the on-screen instructions.

Performing a recovery

In case of system failure or instability, the computer provides the following tools to recover your files:

- Windows recovery tools (select models only): You can use the Windows Backup utility to recover information you have previously backed up.
- *Operating System* and *Driver Recovery* discs (included with your computer): You can use the discs to recover your operating system and programs installed at the factory.

Recovering your information

To recover information you previously backed up, follow these steps:

1. If possible, back up all personal files.
2. Select **Start > All Programs > Accessories > System Tools > Backup**.
The Backup or Restore Wizard opens.
3. Click **Restore files and settings**, and then click **Next**.
4. Follow the on-screen instructions.



For additional information on initiating a recovery in Windows, perform a search for this topic in Help and Support.

Recovering the operating system and programs



CAUTION: The recovery process reformats and completely erases the hard drive. All files you have created and any software installed on the computer are permanently removed. The recovery process reinstalls the original operating system, software, and drivers. Software, drivers, and updates not installed by HP must be manually reinstalled.

To recover your operating system and programs, follow these steps:

1. If possible, back up all personal files.
2. Insert the *Operating System* disc into the optical drive.
3. Shut down the computer.
4. Turn on the computer.
5. Follow the on-screen instructions to install the operating system.
6. After the operating system is installed, remove the *Operating System* disc and insert the *Driver Recovery* disc.
7. Follow the on-screen instructions to install the drivers and programs.

Connector pin assignments

Audio-out (headphone)/Audio-in (microphone)

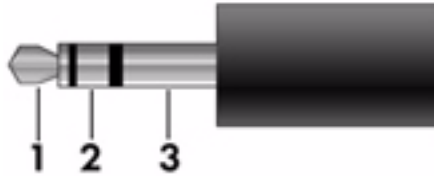

Pin	Signal
1	Audio out, left channel
2	Audio out, right channel
3	Ground

External monitor

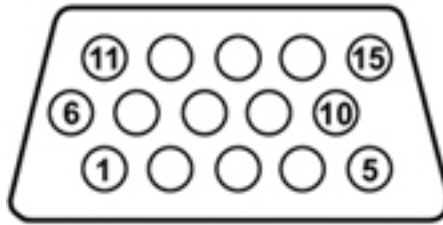

Pin	Signal
1	Red analog
2	Green analog
3	Blue analog
4	Not connected
5	Ground
6	Ground analog
7	Ground analog
8	Ground analog
9	+5 VDC
10	Ground
11	Monitor detect
12	DDC 2B data
13	Horizontal sync
14	Vertical sync
15	DDC 2B clock

HDMI

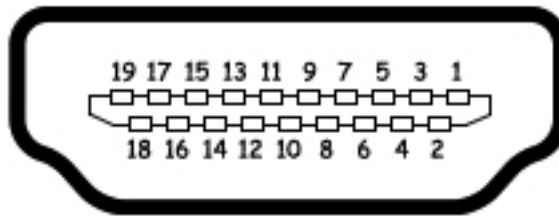

Pin	Signal
1	TMDS data 2+
2	TMDS data 2 shield
3	TMDS data 2-
4	TMDS data 1+
5	TMDS data 1 shield
6	TMDS data 1-
7	TMDS data 0+
8	TMDS data 0 shield
9	TMDS data 0-
10	TMDS clock+
11	TMDS clock shield
12	TMDS clock-
13	CEC
14	No connect
15	DDC clock
16	DDC data
17	Ground
18	+5V power
19	Hot plug detect

RJ-45 (network)

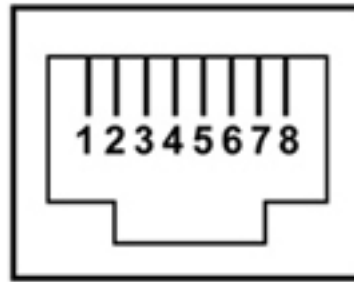

Pin	Signal
1	Transmit +
2	Transmit -
3	Receive +
4	Unused
5	Unused
6	Receive -
7	Unused
8	Unused

Universal Serial Bus

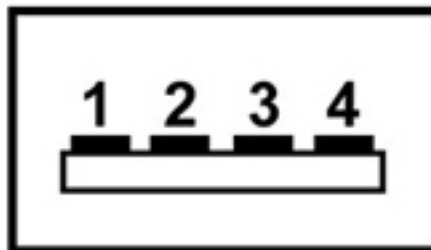

Pin	Signal
1	+5 VDC
2	Data
3	Data +
4	Ground

Power cord set requirements

The wide-range input feature of the computer permits it to operate from any line voltage from 100 to 120 volts AC, or from 220 to 240 volts AC.

The 3-conductor power cord set included with the computer meets the requirements for use in the country or region where the equipment is purchased.

Power cord sets for use in other countries and regions must meet the requirements of the country or region where the computer is used.

Requirements for all countries and regions

The following requirements are applicable to all countries and regions:

- The length of the power cord set must be at least 1.5 m (5.0 ft) and no more than 2.0 m (6.5 ft).
- All power cord sets must be approved by an acceptable accredited agency responsible for evaluation in the country or region where the power cord set will be used.
- The power cord sets must have a minimum current capacity of 10 amps and a nominal voltage rating of 125 or 250 V AC, as required by the power system of each country or region.
- The appliance coupler must meet the mechanical configuration of an EN 60 320/IEC 320 Standard Sheet C13 connector for mating with the appliance inlet on the back of the computer.

Requirements for specific countries and regions

Country/region	Accredited agency	Applicable note number
Australia	EANSW	1
Austria	OVE	1
Belgium	CEBC	1
Canada	CSA	2
Denmark	DEMKO	1
Finland	FIMKO	1
France	UTE	1
Germany	VDE	1
Italy	IMQ	1
Japan	METI	3
The Netherlands	KEMA	1
Norway	NEMKO	1
The People's Republic of China	CCC	5
South Korea	EK	4
Sweden	SEMKO	1
Switzerland	SEV	1
Taiwan	BSMI	4
The United Kingdom	BSI	1
The United States	UL	2

1. The flexible cord must be Type HO5VV-F, 3-conductor, 1.0-mm² conductor size. Power cord set fittings (appliance coupler and wall plug) must bear the certification mark of the agency responsible for evaluation in the country or region where it will be used.
2. The flexible cord must be Type SPT-3 or equivalent, No. 18 AWG, 3-conductor. The wall plug must be a two-pole grounding type with a NEMA 5-15P (15 A, 125 V) or NEMA 6-15P (15 A, 250 V) configuration.
3. The appliance coupler, flexible cord, and wall plug must bear a "T" mark and registration number in accordance with the Japanese Dentori Law. The flexible cord must be Type VCT or VCTF, 3-conductor, 1.00-mm² conductor size. The wall plug must be a two-pole grounding type with a Japanese Industrial Standard C8303 (7 A, 125 V) configuration.
4. The flexible cord must be Type RVV, 3-conductor, 0.75-mm² conductor size. Power cord set fittings (appliance coupler and wall plug) must bear the certification mark of the agency responsible for evaluation in the country or region where it will be used.
5. The flexible cord must be Type VCTF, 3-conductor, 0.75-mm² conductor size. Power cord set fittings (appliance coupler and wall plug) must bear the certification mark of the agency responsible for evaluation in the country or region where it will be used.

Battery

When a battery has reached the end of its useful life, do not dispose of the battery in general household waste. Follow the local laws and regulations in your area for computer battery disposal.

Display

 **WARNING:** The backlight contains mercury. Caution must be exercised when removing and handling the backlight to avoid damaging this component and causing exposure to the mercury.

 **CAUTION:** The procedures in this chapter can result in damage to display components. The only components intended for recycling purposes are the liquid crystal display (LCD) panel and the backlight. When you remove these components, handle them carefully.

 **Materials Disposal.** This HP product contains mercury in the backlight in the display assembly that might require special handling at end-of-life. Disposal of mercury may be regulated because of environmental considerations. For disposal or recycling information, contact your local authorities, or see the Electronic Industries Alliance (EIA) Web site at <http://www.eiae.org>.

This section provides disassembly instructions for the display assembly. The display assembly must be disassembled to gain access to the backlight ❶ and the liquid crystal display (LCD) panel ❷.



 The procedures provided in this chapter are general disassembly instructions. Specific details, such as screw sizes, quantities, and locations, and component shapes and sizes, can vary from one computer model to another.

Perform the following steps to disassemble the display assembly:

1. Remove all screw covers ① and screws ② that secure the display bezel to the display assembly.

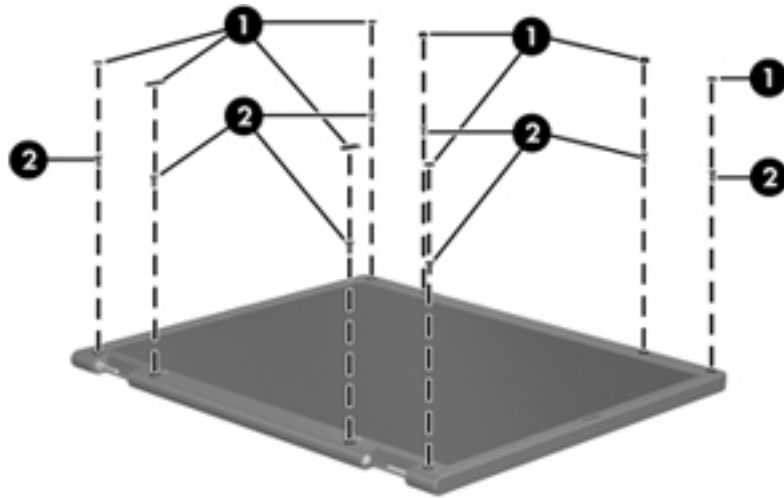

2. Lift up and out on the left and right inside edges ① and the top and bottom inside edges ② of the display bezel until the bezel disengages from the display assembly.
3. Remove the display bezel ③.

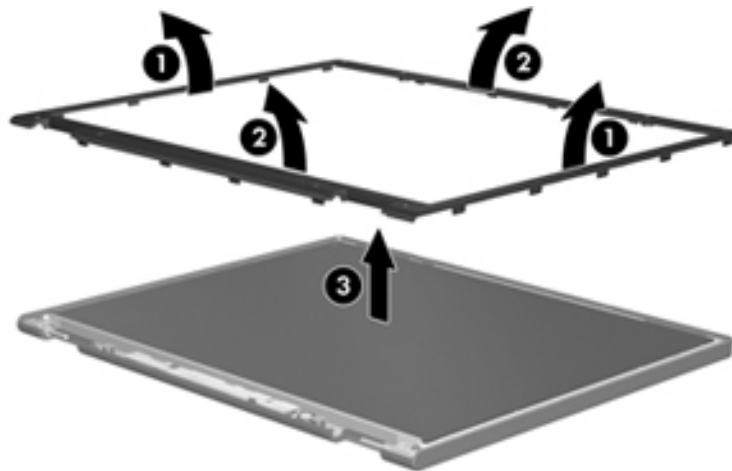

4. Disconnect all display panel cables ① from the display inverter and remove the inverter ②.

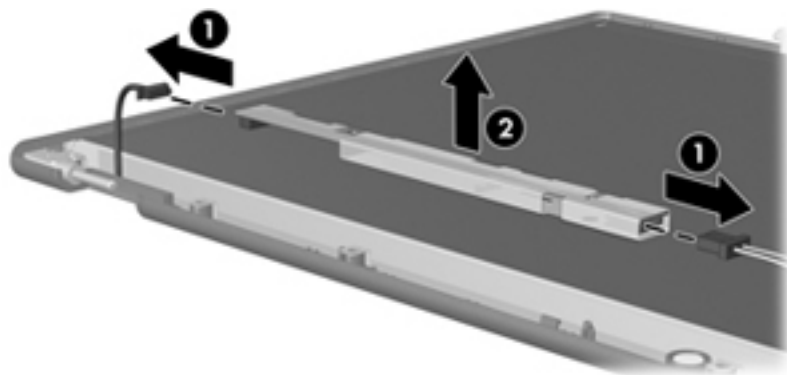

5. Remove all screws ❶ that secure the display panel assembly to the display enclosure.
6. Remove the display panel assembly ❷ from the display enclosure.

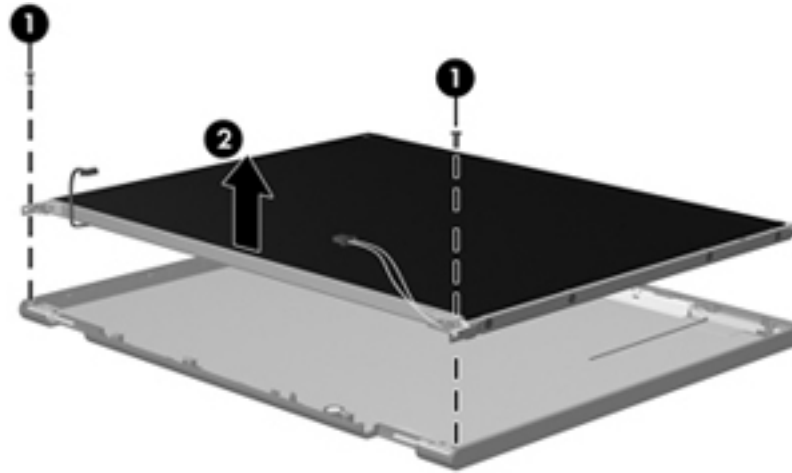

7. Turn the display panel assembly upside down.
8. Remove all screws that secure the display panel frame to the display panel.

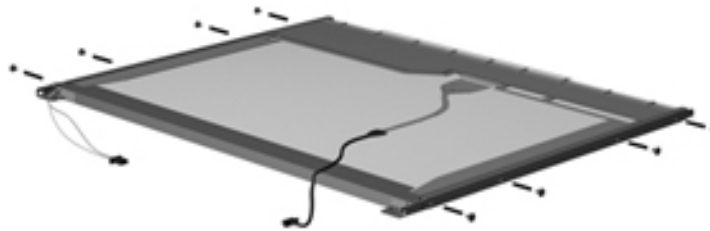

9. Use a sharp-edged tool to cut the tape ❶ that secures the sides of the display panel to the display panel frame.
10. Remove the display panel frame ❷ from the display panel.

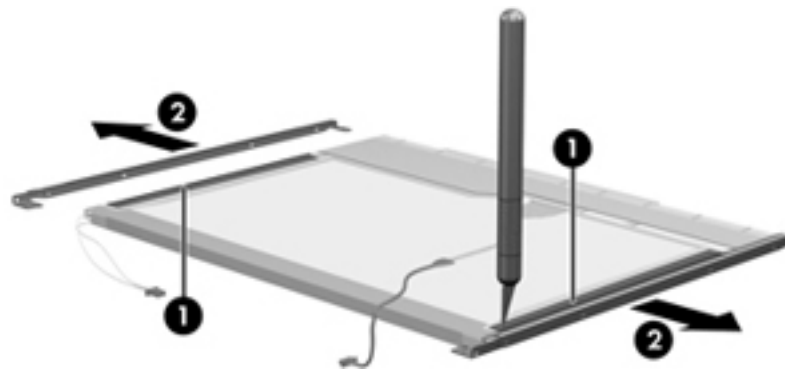

11. Remove the screws ❶ that secure the backlight cover to the display panel.
12. Lift the top edge of the backlight cover ❷ and swing it outward.

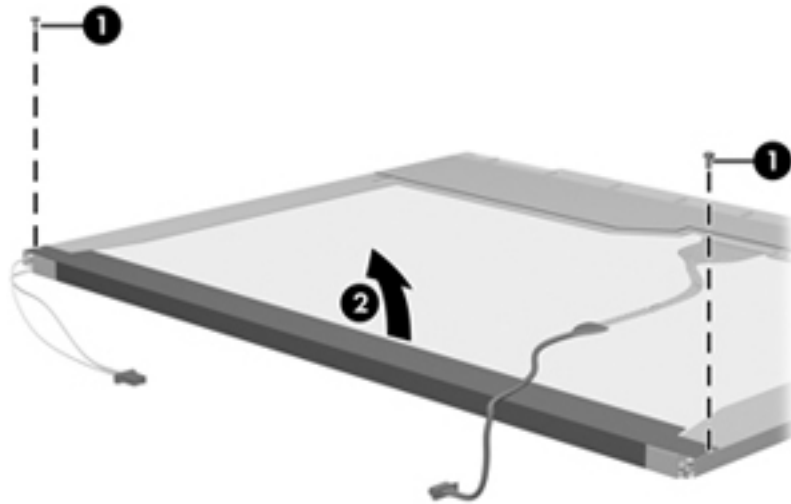

13. Remove the backlight cover.
14. Turn the display panel right-side up.
15. Remove the backlight cables ❶ from the clip ❷ in the display panel.

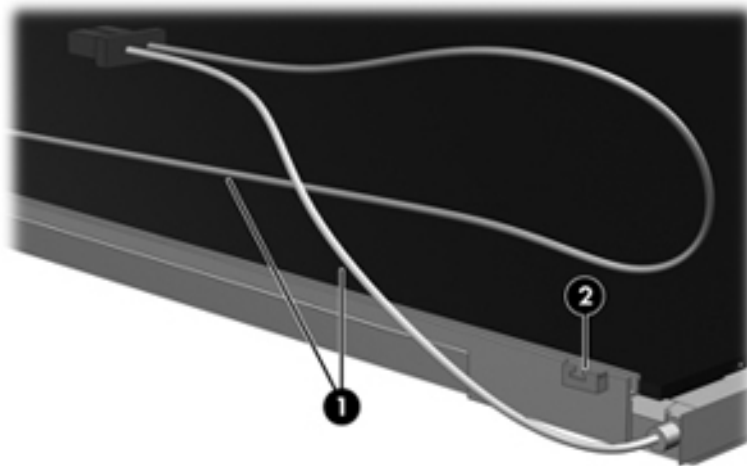

16. Turn the display panel upside down.
17. Remove the backlight frame from the display panel.



WARNING: The backlight contains mercury. Exercise caution when removing and handling the backlight to avoid damaging this component and causing exposure to the mercury.

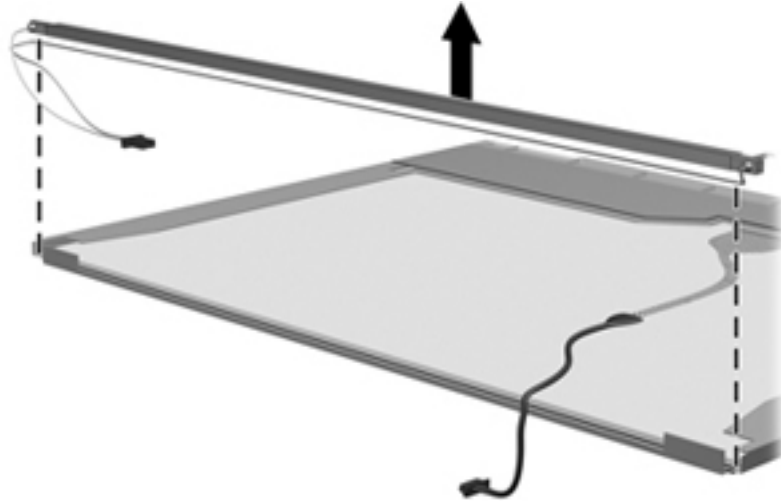

18. Remove the backlight from the backlight frame.

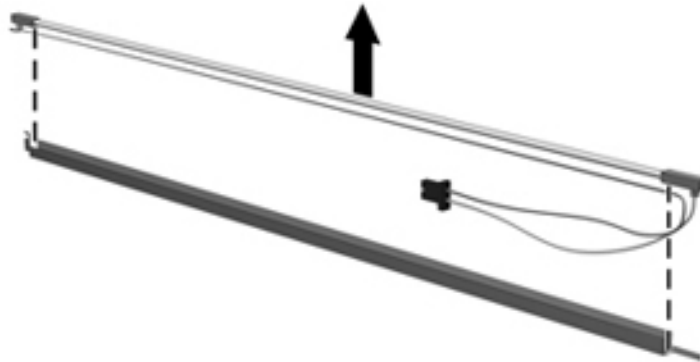

19. Disconnect the display cable ❶ from the LCD panel.
20. Remove the screws ❷ that secure the LCD panel to the display rear panel.
21. Release the LCD panel ❸ from the display rear panel.
22. Release the tape ❹ that secures the LCD panel to the display rear panel.

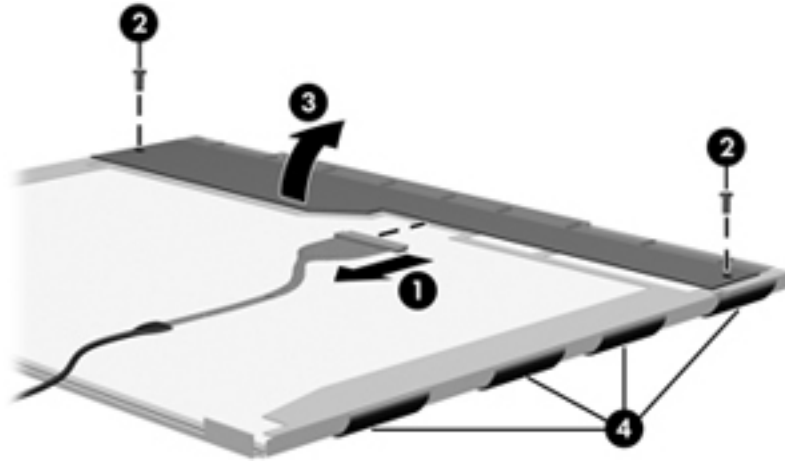

23. Remove the LCD panel.

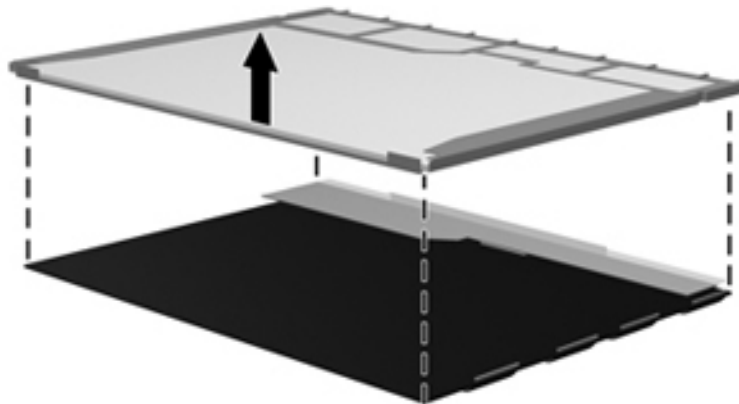

24. Recycle the LCD panel and backlight.

A

- AC adapter, spare part numbers 3-10, 3-11
- antennas
 - disconnecting 4-12, 4-13
 - locations 2-2
- audio, product description 1-3
- audio-in jack, connector pinout 9-1
- audio-out jack, connector pinout 9-1

B

- backing up files 8-2
- base enclosure, spare part number 3-4, 3-15
- battery
 - removal 4-7
 - spare part numbers 3-8, 3-14, 4-7
- battery bay 2-10
- BIOS administrator password 5-3
- Bluetooth module, spare part number 3-4, 3-13, 3-15
- Blu-ray ROM DVD±R/RW SuperMulti Double-Layer Drive
 - precautions 4-2
 - spare part number 3-10, 3-14
- Blu-ray ROM with LightScribe DVD±R/RW SuperMulti DL Drive, specifications 6-5
- boot options 5-4
- boot order 5-4
- bottom components 2-10
- buttons
 - power 2-3
 - TouchPad 2-6
 - wireless 2-3

C

- Cable Kit, spare part number 3-4, 3-16
- cables, service considerations 4-1
- caps lock light 2-5
- chipset, product description 1-1
- components
 - bottom 2-10
 - buttons 2-3
 - display 2-1
 - front 2-7
 - keys 2-4
 - left-side 2-9
 - lights 2-5

- pointing device 2-6
 - right-side 2-8
 - top 2-3
 - computer feet
 - locations 4-6
 - spare part number 4-6
 - computer specifications 6-1
 - connector pinout
 - audio-in jack 9-1
 - audio-out jack 9-1
 - external monitor port 9-2
 - HDMI port 9-3
 - headphone jack 9-1
 - microphone jack 9-1
 - modem jack 9-4
 - monitor port 9-2
 - network jack 9-4
 - RJ-11 jack 9-4
 - RJ-45 jack 9-4
 - USB port 9-4
 - connectors, service considerations 4-1
- ## D
- Diagnostics menu 5-3
 - diskette drive, product description 1-3
 - display assembly
 - removal 4-31
 - spare part number 3-15
 - spare part numbers 3-3, 3-13, 4-31
 - display bezel
 - illustrated 3-9, 3-13, 4-31
 - removal 4-33
 - spare part numbers 3-9, 3-13, 3-14, 4-31
 - Display Cable Kit
 - illustrated 3-9, 3-13, 4-31
 - spare part numbers 3-9, 3-13, 4-31
 - display components
 - illustrated 2-1
 - recycling 11-1
 - spare part numbers 3-9
 - display enclosure
 - illustrated 3-9, 4-31
 - spare part numbers 3-9, 3-13, 3-14, 4-31
 - display hinges, removal 4-34
 - display inverter, removal 11-2

- display panel cable
 - illustrated 3-9, 3-13, 4-31
 - removal 4-35
 - spare part numbers 3-9, 3-13, 4-31
- display panel, product description 1-2
- display switch 2-1
- drive light 2-7
- drives, boot order 5-4
- DVD±RW and CD-RW SuperMulti Double-Layer Drive
 - precautions 4-2
 - spare part number 3-10, 3-14
 - specifications 6-6
- DVD-ROM Drive
 - precautions 4-2
 - specifications 6-6

E

- electrostatic discharge 4-2
- equipment guidelines 4-4
- esc key 2-4
- Ethernet, product description 1-3
- external media card, product description 1-4
- external monitor port
 - connector pinout 9-2
 - location 2-8

F

- f11 recovery 8-4
- fan
 - removal 4-43
 - spare part number 3-15, 4-43
- feet
 - locations 4-6
 - spare part number 4-6
- File menu 5-3
- fn key 2-4
- front components 2-7
- function keys 2-4

G

- graphics, product description 1-1
- grounding equipment and methods 4-2

H

- hard drive
 - precautions 4-2
 - product description 1-2
 - removal 4-18
 - spare part number 3-15
 - spare part numbers 3-8, 3-14, 3-16, 4-18
 - specifications 6-3
- hard drive bay 2-10
- hard drive bracket, removal 4-20

- hard drive connector, removal 4-20
- hard drive hardware kit, spare part numbers 3-14
- hard drive recovery 8-4
- HDMI port, connector pinout 9-3
- headphone jack, connector pinout 9-1
- heat sink
 - removal 4-43
 - spare part number 3-15
 - spare part numbers 4-43
- hinges, removal 4-34

J

- jacks
 - modem 2-9
 - network 2-8
 - RJ-11 2-9
 - RJ-45 2-8

K

- key components 2-4
- keyboard
 - product description 1-4
 - removal 4-21
 - spare part number 3-3, 3-14, 3-15, 4-21
- keys
 - esc 2-4
 - fn 2-4
 - function 2-4
 - Windows applications 2-4
 - Windows logo 2-4

L

- language, changing in Computer Setup 5-4
- left-side components 2-9
- light components 2-5
- lights
 - caps lock 2-5
 - drive 2-7
 - power 2-5
 - webcam 2-1
 - wireless 2-5

M

- memory module
 - removal 4-16
 - spare part numbers 3-4, 3-14, 3-16, 4-16
- memory, product description 1-2
- microphone
 - locations 2-1
 - product description 1-3
- microphone jack, connector pinout 9-1
- model name 3-1, 4-5
- modem jack
 - connector pinout 9-4

- location 2–9
- modem, product description 1–3
- monitor port
 - connector pinout 9–2
 - location 2–8
- multi board
 - spare part numbers 3–16
- N**
- network cable, removal 4–43
- network jack
 - connector pinout 9–4
 - location 2–8
- O**
- operating system, product description 1–5
- optical drive
 - precautions 4–2
 - product description 1–3
 - spare part numbers 3–10
 - specifications 6–5, 6–6
- P**
- packing guidelines 4–3
- passwords 5–3
- plastic parts 4–1
- Plastics Kit
 - contents 3–10
 - spare part number 3–4, 3–15
- pointing device
 - components 2–6
 - illustrated 2–6
 - product description 1–4
- ports
 - external monitor 2–8
 - monitor 2–8
 - product description 1–4
 - USB 2–8, 2–9
- power button board
 - removal 4–38
 - spare part numbers 3–4, 3–15, 4–38
- power connector 2–9
- power connector cable, removal 4–38
- power cord
 - set requirements 10–1
 - spare part numbers 3–10, 3–11
- power light 2–5
- power requirements, product description 1–4
- processor, product description 1–1
- product description
 - audio 1–3
 - chipset 1–1
 - diskette drive 1–3
 - display panel 1–2

- Ethernet 1–3
- external media card 1–4
- graphics 1–1
- hard drive 1–2
- keyboard 1–4
- memory 1–2
- microphone 1–3
- modem 1–3
- operating system 1–5
- optical drive 1–3
- pointing device 1–4
- ports 1–4
- power requirements 1–4
- processor 1–1
- security 1–5
- serviceability 1–5
- webcam 1–3
- wireless 1–4
- product name 3–1, 4–5
- R**
- recovering information 8–4
- recovery, system 8–1
- recycling
 - battery 11–1
 - display components 11–1
- removal/replacement
 - preliminaries 4–1
 - procedures 4–5
- restoring factory settings 5–2
- right-side components 2–8
- RJ-11 jack
 - connector pinout 9–4
 - location 2–9
- RJ-45 jack
 - connector pinout 9–4
 - location 2–8
- RTC battery
 - removal 4–15
 - spare part number 3–4, 3–15, 4–15
- Rubber Feet Kit, spare part number 3–10, 3–15, 4–6
- S**
- Screw Kit, spare part number 3–10, 3–15
- screw listing 7–1
- Security menu 5–3
- Security menu, set up BIOS administrator password 5–3
- security, product description 1–5
- service considerations 4–1
- serviceability, product description 1–5
- Setup Utility
 - accessing 5–1

- Diagnostics menu 5–3
 - File menu 5–3
 - navigating and selecting 5–1
 - restoring factory settings 5–2
 - Security menu 5–3
 - System Configuration menu 5–4
 - using 5–1
 - SIM, removal 4–8
 - sleeve
 - spare part number 3–15
 - solid state drive
 - spare part number 3–15
 - speakers
 - removal 4–29
 - spare part number 3–4, 3–15, 4–29
 - specifications
 - Blu-ray ROM with LightScribe DVD±R/RW SuperMulti DL Drive 6–5
 - computer 6–1
 - display assembly 6–2
 - DVD±RW and CD-RW SuperMulti Double-Layer Drive 6–6
 - DVD-ROM Drive 6–6
 - hard drive 6–3
 - optical drive 6–5, 6–6
 - system DMA 6–6
 - system I/O address 6–8
 - system interrupt 6–7
 - system memory map 6–6
 - switch cover
 - removal 4–21
 - spare part numbers 4–21
 - system board
 - removal 4–38
 - spare part number 3–15
 - spare part numbers 3–4, 3–13, 4–38
 - System Configuration menu 5–4
 - system DMA specifications 6–6
 - system I/O address specifications 6–8
 - system interrupt specifications 6–7
 - system memory map specifications 6–6
 - system recovery 8–1
- T**
- tools required 4–1
 - top components 2–3
 - top cover
 - removal 4–24
 - spare part numbers 3–3, 3–15, 4–24
 - TouchPad 2–6
 - TouchPad buttons 2–6
 - TouchPad scroll zone 2–6
- U**
- Universal Serial Bus (USB) port
 - connector pinout 9–4
 - location 2–8, 2–9
 - USB board
 - removal 4–37
 - spare part number 4–37
- V**
- vents 2–10
- W**
- warranty period 3–1, 4–5
 - webcam 2–1
 - webcam light 2–1
 - webcam module
 - illustrated 3–9, 3–13, 4–31
 - removal 4–34
 - spare part number 3–9, 3–13, 4–31
 - webcam, product description 1–3
 - Windows applications key 2–4
 - Windows logo key 2–4
 - wireless antennas
 - disconnecting 4–12, 4–13
 - locations 2–2
 - wireless light 2–5
 - wireless, product description 1–4
 - WLAN module
 - removal 4–9
 - spare part numbers 3–5, 3–11, 3–12, 3–13, 4–9
 - workstation guidelines 4–3
 - WWAN module
 - removal 4–13
 - spare part numbers 3–4, 4–13